



Part No. IB036603  
Dec 2024



01189 786911 TELONIC.CO.UK

# Communication Interface Manual

Bidirectional DC Power Supply  
PXB Series

**PXB20K-50**

**PXB20K-250**

**PXB20K-500**

**PXB20K-1000**

**PXB20K-1500**



# Contents

<b>Command List</b> .....	<b>7</b>	ABOR:ACQ .....	57
<b>Introduction</b> .....	<b>17</b>	ABOR:TRAN .....	57
About This Manual .....	17	<b>ANALog Command</b> .....	<b>58</b>
States of Panel Operation and Remote Op- eration .....	18	ANAL:CONT:SEL:RANG .....	58
<b>Setup</b> .....	<b>19</b>	ANAL:CONT:VOLT:RANG .....	59
Installing a VISA Library .....	19	ANAL:MON:CURR:RANG .....	59
Setting Up the Interface .....	19	ANAL:MON:VOLT:RANG .....	60
Accessing and Operating the Product from a Web Browser .....	25	<b>DATA Command</b> .....	<b>61</b>
Preparation for Multichannel .....	41	DATA:INT:GATE .....	61
<b>About Commands</b> .....	<b>45</b>	DATA:INT:GATE:RES .....	62
Command Hierarchy .....	45	DATA:INT:RES .....	62
Command Syntax .....	46	DATA:INT:STAR .....	62
<b>IEEE 488.2 Common Commands</b> ...	<b>50</b>	DATA:INT:STOP .....	62
*CLS .....	50	DATA:REM? .....	63
*ESE .....	50	DATA:REM:POIN? .....	63
*ESR? .....	50	<b>DIAGnostic Command</b> .....	<b>64</b>
*IDN? .....	51	DIAG:FIRM:VERS? .....	64
*OPC .....	51	DIAG:LINE:POW? .....	64
*OPT? .....	51	<b>DISPlay Command</b> .....	<b>65</b>
*PSC .....	52	DISP:BRIG .....	65
*RCL .....	52	<b>GLOBal command</b> .....	<b>66</b>
*RST .....	52	GLOB:OUTP .....	66
*SAV .....	53	<b>INITiate Command</b> .....	<b>67</b>
*SRE .....	53	INIT:ACQ .....	67
*STB? .....	53	INIT:TRAN:PROG .....	67
*TRG .....	54	<b>INSTrument Command</b> .....	<b>68</b>
*TST? .....	54	INST .....	68
*WAI .....	54	INST:CAT? .....	68
List of Parameters Applicable to *RCL, *RST, and *SAV and Each Setting Com- mand .....	55	INST:INFO? .....	69
<b>ABORt Command</b> .....	<b>57</b>		
ABOR .....	57		

<b>IO Command . . . . .</b>	<b>70</b>	PROG:CHA:CAT? . . . . .	87
IO:INP:FILT . . . . .	70	PROG:CHA:CLE . . . . .	87
IO:INP:FUNC . . . . .	71	PROG:CURR:FUNC:MODE . . . . .	88
IO:INP:POL . . . . .	72	PROG:POW:FUNC:MODE . . . . .	89
IO:OUTP:FUNC . . . . .	73	PROG:DEL . . . . .	89
IO:OUTP:POL . . . . .	74	PROG:DEL:ALL . . . . .	89
IO:STAT . . . . .	74	PROG:LOOP . . . . .	90
<b>MEASure / READ / FETCh Command 75</b>		PROG:NAME . . . . .	91
MEAS? / READ? / FETC? . . . . .	75	PROG:REN . . . . .	92
MEAS:ALL? / READ:ALL? / FETC:ALL? . . . . .	75	PROG:SAVE . . . . .	92
MEAS:CAP? / READ:CAP? / FETC:CAP? . . . . .	76	PROG:STEP:COUN . . . . .	93
MEAS:CURR? / READ:CURR? / FETC:CURR? . . . . .	76	PROG:STEP<n>:CURR . . . . .	93
MEAS:ENER? / READ:ENER? / FETC:ENER? . . . . .	76	PROG:STEP<n>:CURR:NEG . . . . .	94
MEAS:ETIM? / READ:ETIM? / FETC:ETIM? . . . . .	77	PROG:STEP<n>:CURR:SEAM . . . . .	94
MEAS:POW? / READ:POW? / FETC:POW? . . . . .	77	PROG:STEP<n>:POW . . . . .	95
MEAS:VOLT? / READ:VOLT? / FETC:VOLT? . . . . .	77	PROG:STEP<n>:POW:NEG . . . . .	95
<b>MEMory Command . . . . .</b>	<b>78</b>	PROG:STEP<n>:POW:SEAM . . . . .	96
MEM:CLE . . . . .	78	PROG:STEP<n>:RES:IR . . . . .	96
MEM:REC . . . . .	78	PROG:STEP<n>:VOLT . . . . .	97
MEM:REC:CONF . . . . .	79	PROG:STEP<n>:DEL . . . . .	97
MEM:REC:PREV? . . . . .	79	PROG:STEP<n>:DWEL . . . . .	98
MEM:SAVE . . . . .	80	PROG:STEP<n>:EDIT . . . . .	99
<b>OUTPut Command . . . . .</b>	<b>81</b>	PROG:STEP<n>:FUNC:MODE . . . . .	100
OUTP . . . . .	81	PROG:STEP<n>:INS . . . . .	100
OUTP:MSYN . . . . .	82	PROG:STEP<n>:OUTP . . . . .	101
OUTP:MSYN:ACC . . . . .	83	PROG:STEP<n>:OUTP:MODE:TRAN . . . . .	102
OUTP:PON . . . . .	83	PROG:STEP<n>:RAMP . . . . .	103
OUTP:PROT:CLE . . . . .	84	PROG:STEP<n>:TRIG:GEN . . . . .	104
OUTP:PROT:RSEN . . . . .	84	PROG:STEP<n>:TRIG:WAIT . . . . .	105
OUTP:PROT:WDOG . . . . .	84	<b>SENSe Command . . . . .</b>	<b>106</b>
OUTP:PROT:WDOG:DEL . . . . .	85	SENS:APER . . . . .	106
<b>PROGram Command . . . . .</b>	<b>86</b>	<b>SOURce:FUNCtion Command . . . . .</b>	<b>107</b>
PROG:ALL:STEP:COUN? . . . . .	86	FUNC:MODE . . . . .	107
PROG:CAT? . . . . .	86	FUNC:OFF:MODE . . . . .	107
PROG:CHA:ADD . . . . .	87	<b>SOURce:CURRent Command . . . . .</b>	<b>108</b>
		CURR . . . . .	108
		CURR:NEG . . . . .	108
		CURR:FUNC:MODE . . . . .	109

CURR:IV:CAT? .....	109	VOLT:IV:MAP<n>:INS .....	131
CURR:IV:CLE .....	110	VOLT:PROT .....	131
CURR:IV:COUN .....	110	VOLT:PROT:LOW .....	132
CURR:IV:DATA .....	111	VOLT:PROT:LOW:STAT .....	132
CURR:IV:MAP<n> .....	113	VOLT:PULS:DCYC .....	133
CURR:IV:MAP<n>:DEL .....	113	VOLT:PULS:FREQ .....	133
CURR:IV:MAP<n>:INS .....	114	VOLT:PULS:HIGH .....	134
CURR:PROT .....	114	VOLT:PULS:LOW .....	134
CURR:NEG:PROT .....	114	VOLT:RESP .....	135
CURR:PROT:DEL .....	115	VOLT:SINE:AMPL .....	135
CURR:PULS:DCYC .....	115	VOLT:SINE:FREQ .....	136
CURR:PULS:FREQ .....	116	VOLT:SINE:OFFS .....	136
CURR:PULS:HIGH .....	116	VOLT:SLEW .....	137
CURR:PULS:LOW .....	117	<b>TRIGger Command .....</b>	<b>138</b>
CURR:RESP .....	117	TRIG:ACQ .....	138
CURR:SEAM .....	118	TRIG:ACQ:COUN .....	138
CURR:SINE:AMPL .....	118	TRIG:ACQ:DEL .....	139
CURR:SINE:FREQ .....	119	TRIG:ACQ:INT:STAT .....	139
CURR:SINE:OFFS .....	119	TRIG:ACQ:INT:TIME .....	140
CURR:SLEW .....	120	TRIG:ACQ:MSYN .....	140
<b>SOURce:POWer Command .....</b>	<b>121</b>	TRIG:ACQ:SOUR .....	141
POW .....	121	TRIG:TRAN .....	141
POW:NEG .....	121	TRIG:TRAN:EXEC? .....	142
POW:FUNC:MODE .....	122	TRIG:TRAN:MSYN .....	142
POW:PROT .....	122	TRIG:TRAN:PAUS .....	142
POW:NEG:PROT .....	123	TRIG:TRAN:RES .....	143
POW:SEAM .....	123	TRIG:TRAN:SOUR .....	143
<b>SOURce:RESistance Command .....</b>	<b>124</b>	<b>SYSTEM Command .....</b>	<b>144</b>
RES:IR .....	124	SYST:BEEP .....	144
<b>SOURce:VOLTage Command .....</b>	<b>125</b>	SYST:BEEP:KEY .....	144
VOLT .....	125	SYST:BEEP:PROT .....	145
VOLT:FUNC:MODE .....	126	SYST:BEEP:SCPI .....	145
VOLT:IV:CAT? .....	126	SYST:COMM:RLST .....	146
VOLT:IV:CLE .....	127	SYST:DATE .....	147
VOLT:IV:COUN .....	127	SYST:ERR? .....	147
VOLT:IV:DATA .....	128	SYST:ERR:COUN? .....	148
VOLT:IV:MAP<n> .....	130	SYST:KLOC .....	148
VOLT:IV:MAP<n>:DEL .....	130	SYST:KLOC:LEV .....	149
		SYST:MSYN? .....	149

SYST:PARA:UNIT:COUN? .....	150	QUESTionable:INSTrument Sub Register ..	168
SYST:PON .....	150	STAT:QUES:INST? .....	168
SYST:PON:REC .....	150	STAT:QUES:INST:COND? .....	168
SYST:PROT:LINE:VOLT .....	151	STAT:QUES:INST:ENAB .....	169
SYST:RSEN .....	151	STAT:QUES:INST:NTR .....	169
SYST:TIME .....	152	STAT:QUES:INST:PTR .....	169
SYST:TIME:ADJ .....	152	QUESTionable:INSTrument:ISUMmary<n> Sub Register .....	170
SYST:TZON .....	152	STAT:QUES:INST:ISUM<n>? .....	170
SYST:TZON:CAT? .....	153	STAT:QUES:INST:ISUM<n>:COND? .....	171
SYST:VERS? .....	153	STAT:QUES:INST:ISUM<n>:ENAB .....	171
<b>STATus Command .....</b>	<b>154</b>	STAT:QUES:INST:ISUM<n>:NTR .....	171
Status Report Structure .....	154	STAT:QUES:INST:ISUM<n>:PTR .....	172
Standard Architecture .....	156	Preset Status .....	172
Status Byte Register .....	157	STAT:PRES .....	172
Event Status Register .....	158	<b>Tutorial .....</b>	<b>173</b>
OPERation Status Register .....	159	Basic Configuration .....	173
STAT:OPER? .....	159	Measuring .....	174
STAT:OPER:COND? .....	159	Overview of Trigger Function .....	175
STAT:OPER:ENAB .....	160	Waiting for Operation Complete .....	181
STAT:OPER:NTR .....	160	Status Monitoring .....	182
STAT:OPER:PTR .....	160	Use Multichannel .....	183
OPERation:INSTrument Sub Register .....	161	Error Checking .....	183
STAT:OPER:INST? .....	161	When Using Commands on a PLC (se- quencer, controller) .....	184
STAT:OPER:INST:COND? .....	161	<b>Appendix .....</b>	<b>185</b>
STAT:OPER:INST:ENAB .....	162	List of Errors .....	185
STAT:OPER:INST:NTR .....	162	Command Processing Time .....	188
STAT:OPER:INST:PTR .....	162		
OPERation:INSTrument:ISUMmary<n> Sub Register .....	163		
STAT:OPER:INST:ISUM<n>? .....	163		
STAT:OPER:INST:ISUM<n>:COND? .....	164		
STAT:OPER:INST:ISUM<n>:ENAB .....	164		
STAT:OPER:INST:ISUM<n>:NTR .....	164		
STAT:OPER:INST:ISUM<n>:PTR .....	165		
QUESTionable Status Register .....	166		
STAT:QUES? .....	166		
STAT:QUES:COND? .....	166		
STAT:QUES:ENAB .....	167		
STAT:QUES:NTR .....	167		
STAT:QUES:PTR .....	167		

# Command List

## IEEE 488.2 Common Commands

### \*CLS

Clears all event registers including the status byte, event status, and error queue. (p.50)

### \*ESE

Sets the event status enable register that is counted by the event summary bit (ESB) of the status byte. (p.50)

### \*ESR?

Queries the event status register. (p.50)

### \*IDN?

Queries the model name and firmware version of this product. (p.51)

### \*OPC

Sets the OPC bit (bit 0) of the event status register when all the commands that are in standby have been processed. (p.51)

### \*OPT?

Queries the installed options. (p.51)

### \*PSC

Sets whether the event status enable register and service request enable register are cleared when the POWER switch is turned on. (p.52)

### \*RCL

Recalls setup memories. (p.52)

### \*RST

Resets the panel settings. (p.52)

### \*SAV

Saves the panel settings to the setup memory. (p.53)

### \*SRE

Sets the service request enable register. (p.53)

### \*STB?

Queries the contents of the status byte register and the MSS (master summary status) message. (p.53)

### \*TRG

Trigger command. (p.54)

### \*TST?

Executes a self-test. (p.54)

### \*WAI

Prevents the PXB series from executing subsequent commands until all operations that are in standby have completed. (p.54)

## ABORt Command

### ABOR

Aborts measurement operations and sequence operations. (p.57)

### ABOR:ACQ

Aborts measurement operations. (p.57)

### ABOR:TRAN

Cancel the sequence operation. (p.57)

## ANALog Command

### ANAL:CONT:SEL:RANG

Sets the voltage range of the signal input to the EXT CONT connector when externally controlling the output from the DC OUTPUT terminal in the CC or CP mode. (p.58)

### ANAL:CONT:VOLT:RANG

Sets the voltage range of the signals to the EXT CONT connector when this product is controlled externally in the CV mode. (p.59)

### ANAL:MON:Curr:RANG

Sets the voltage range of the signal from the EXT CONT connector when this product is controlled externally in the CC mode. (p.59)

**ANAL:MON:VOLT:RANG**

Sets the voltage range of the signal from the EXT CONT connector when this product is controlled externally in the CV mode. (p.60)

**DATA Command****DATA:INT:GATE**

Sets the period of recording the integrated values. (p.61)

**DATA:INT:GATE:RES**

Sets the condition to reset the recorded integrated value. (p.62)

**DATA:INT:RES**

Resets all integrated values (for integrated current, integrated power, and elapsed time). (p.62)

**DATA:INT:STAR**

Starts integrated value recording. (p.62)

**DATA:INT:STOP**

Stops integrated value recording. (p.62)

**DATA:REM?**

Queries the measured values registered in the data logger from oldest to youngest. (p.63)

**DATA:REM:POIN?**

Queries the number of the remaining measured values that can be queried with DATA:REM? (p.63)

**DIAGnostic Command****DIAG:FIRM:VERS?**

Queries the detailed version information on this product. (p.64)

**DIAG:LINE:POW?**

Queries the power of the AC power line. (p.64)

**DISPlay Command****DISP:BRIG**

Sets the intensity of the display. (p.65)

**GLOBAL command****GLOB:OUTP**

For all channels that are configured under the same domain under Multichannel, sets the output ON/OFF by sending OUTP. (p.66)

**INITiate Command****INIT:ACQ**

Initiates measurement. (p.67)

**INIT:TRAN:PROG**

Starts the sequence start trigger function in the program registered in the chain. (p.67)

**INSTrument Command****INST**

Specifies a channel to be controlled. (p.68)

**INST:CAT?**

Queries the list of channels that can be specified in INST. (p.68)

**INST:INFO?**

Queries the rated voltage, rated current, rated power, and model name of the channel specified in INST. (p.69)

**IO Command****IO:INP:FILT**

Sets the input time filter for the digital input of the EXT CONT connector. (p.70)

**IO:INP:FUNC**

Sets the operation to be implemented when a signal is input for the general-purpose digital input of the EXT CONT connector. (p.71)

**IO:INP:POL**

Sets the polarity for the input signal from the digital input of the EXT CONT connector. (p.72)

**IO:OUTP:FUNC**

Sets the operation to be implemented when a signal is output for the general-purpose digital output of the EXT CONT connector. (p.73)

**IO:OUTP:POL**

Sets the polarity of the output signal from the digital output of the EXT CONT connector. (p.74)

**IO:STAT**

Enables/disables the digital I/O of the EXT CONT connector. (p.74)

**MEASure / READ / FETCh Command****MEAS? / READ? / FETC?**

Queries the measurement results. (p.75)

**MEAS:ALL? / READ:ALL? / FETC:ALL?**

Queries the measurement results. (p.75)

**MEAS:CAP? / READ:CAP? / FETC:CAP?**

Queries the measured current capacity (Ah). (p.76)

**MEAS:CURR? / READ:CURR? / FETC:CURR?**

Queries the measured current (A). (p.76)

**MEAS:ENER? / READ:ENER? / FETC:ENER?**

Queries the measured power capacity (Wh). (p.76)

**MEAS:ETIM? / READ:ETIM ? / FETC:ETIM?**

Queries the measured elapsed time (s). (p.77)

**MEAS:POW? / READ:POW? / FETC:POW?**

Queries the measured power (W). (p.77)

**MEAS:VOLT? / READ:VOLT? / FETC:VOLT?**

Queries the measured voltage (V). (p.77)

**MEMory Command****MEM:CLE**

Returns this product to its factory default settings. (p.78)

**MEM:REC**

Recalls the settings from a desired preset memory. (p.78)

**MEM:REC:CONF**

Enables/disables the confirmation when the settings in a preset memory are recalled. (p.79)

**MEM:REC:PREV?**

Queries the settings stored in a desired preset memory. (p.79)

**MEM:SAVE**

Saves the settings to a desired preset memory. (p.80)

**OUTPut Command****OUTP**

Sets on/off of the output from the DC OUTPUT terminal. (p.81)

**OUTP:MSYN**

Sends a sync signal of output ON or output OFF. (p.82)

**OUTP:MSYN:ACC**

Enables or disables sending/receiving output ON/OFF sync signal (OUTP:MSYN). (p.83)

**OUTP:PON**

Sets the output state when the power supply is turned on. (p.83)

**OUTP:PROT:CLE**

Clears LOW alarm. (p.84)

**OUTP:PROT:RSEN**

Enables/disables Incorrect sensing connection detection (SENS). (p.84)

**OUTP:PROT:WDOG**

Enables/disables communication error protection (WDOG). (p.84)

**OUTP:PROT:WDOG:DEL**

Sets the delay time before the communication error protection (WDOG) is activated. (p.85)

**PROG:Program Command****PROG:ALL:STEP:COUN?**

Queries the total number of registered steps. (p.86)

**PROG:CAT?**

Queries a list of registered programs. (p.86)

**PROG:CHA:ADD**

Adds a program to the chain. (p.87)

**PROG:CHA:CAT?**

Queries the list of programs registered in the chain. (p.87)

**PROG:CHA:CLE**

Unlocks all programs registered in the chain. (p.87)

**PROG:CURR:FUNC:MODE**

Sets the output mode of the program selected in PROG:NAME in CC mode. (p.88)

**PROG:POW:FUNC:MODE**

Sets the output mode of the program selected in PROG:NAME in CP mode. (p.89)

**PROG:DEL**

Deletes the program selected in PROG:NAME. (p.89)

**PROG:DEL:ALL**

Deletes all programs saved in the PXB series. (p.89)

**PROG:LOOP**

Sets the repetition count of the program selected in PROG:NAME. (p.90)

**PROG:NAME**

Creates/selects/deselects a new program. (p.91)

**PROG:REN**

Changes the name of the program selected in PROG:NAME. (p.92)

**PROG:SAVE**

Saves the program selected in PROG:NAME. (p.92)

**PROG:STEP:COUN**

Sets the number of steps to be registered to the program selected in PROG:NAME. (p.93)

**PROG:STEP<n>:CURR**

Sets the current on the source side at the specified step of the program selected in PROG:NAME. (p.93)

**PROG:STEP<n>:CURR:NEG**

Sets the current on the sink side at the specified step of the program selected in PROG:NAME. (p.94)

**PROG:STEP<n>:CURR:SEAM**

Sets the current of the seamless operation in CC mode at the specified step of the program selected in PROG:NAME. (p.94)

**PROG:STEP<n>:POW**

Sets the power on the source side at the specified step of the program selected in PROG:NAME. (p.95)

**PROG:STEP<n>:POW:NEG**

Sets the power on the sink side at the specified step of the program selected in PROG:NAME. (p.95)

**PROG:STEP<n>:POW:SEAM**

Sets the power of the seamless operation in CP mode at the specified step of the program selected in PROG:NAME. (p.96)

**PROG:STEP<n>:RES:IR**

Sets the resistance at the specified step of the program selected in PROG:NAME. (p.96)

**PROG:STEP<n>:VOLT**

Sets the voltage at the specified step of the program selected in PROG:NAME. (p.97)

**PROG:STEP<n>:DEL**

Deletes the specified step of the program selected in PROG:NAME. (p.97)

**PROG:STEP<n>:DWEL**

Sets the step execution time at the specified step of the program selected in PROG:NAME. (p.98)

**PROG:STEP<n>:EDIT**

Sets multiple setting items in a batch for the specified step of the program selected in PROG:NAME. (p.99)

**PROG:STEP<n>:FUNC:MODE**

Sets the output mode at the specified step of the program selected in PROG:NAME. (p.100)

**PROG:STEP<n>:INS**

Copies the specified step of the program selected in PROG:NAME and inserts it into the previous step. (p.100)

**PROG:STEP<n>:OUTP**

Sets output on/off at the specified step of the program selected in PROG:NAME. (p.101)

**PROG:STEP<n>:OUTP:MODE:TRAN**

Sets whether to perform transition to the next step automatically or not when the operation mode changes at the specified step of the program selected in PROG:NAME. (p.102)

**PROG:STEP<n>:RAMP**

Sets the setting transition method at the specified step of the program selected in PROG:NAME. (p.103)

**PROG:STEP<n>:TRIG:GEN**

Sets whether to perform trigger output at the specified step of the program selected by PROG:NAME. (p.104)

**PROG:STEP<n>:TRIG:WAIT**

Sets trigger wait at the specified step of the program selected in PROG:NAME. (p.105)

**SENSE Command****SENS:APER**

Sets the recording time period per measurement. (p.106)

**SOURCE:FUNCTION Command****FUNC:MODE**

Sets the priority of the operation mode when the OUTPUT ON is selected. (p.107)

**FUNC:OFF:MODE**

Sets the impedance when the output from the DC OUTPUT terminal is off. (p.107)

**SOURCE:CURRENT Command****CURR**

Sets the current on the source side in the CC mode. (p.108)

**CURR:NEG**

Sets the current in absolute value on the sink side in the CC mode. (p.108)

**CURR:FUNC:MODE**

Sets the output function for CC mode. (p.109)

**CURR:IV:CAT?**

Queries voltage and current for all point indexes of the I-V characteristic in CC mode. (p.109)

**CURR:IV:CLE**

Returns the I-V characteristics in CC mode to the factory default setting. (p.110)

**CURR:IV:COUN**

Sets the number of data points of I-V characteristics in CC mode. (p.110)

**CURR:IV:DATA**

Sets the entire I-V characteristics in CC mode in the binary block data format. (p.111)

**CURR:IV:MAP<n>**

Sets the voltage and current for the specified parts (point index) of the I-V characteristics in CC mode. (p.113)

**CURR:IV:MAP<n>:DEL**

Deletes the voltage and current for the specified parts (point index) of the I-V characteristics in CC mode. (p.113)

**CURR:IV:MAP<n>:INS**

Inserts a point index at the specified section of the I-V characteristics in CC mode. (p.114)

**CURR:PROT**

Sets the threshold current for the overcurrent protection (OCP) on the source side. (p.114)

**CURR:NEG:PROT**

Sets the threshold current in absolute value for the overcurrent protection (OCP) on the sink side. (p.114)

**CURR:PROT:DEL**

Sets the delay time after the current exceeding the threshold for the overcurrent protection (OCP) has been detected before the OCP is activated. (p.115)

**CURR:PULS:DCYC**

Sets the duty cycle of the pulse function in CC mode. (p.115)

**CURR:PULS:FREQ**

Sets the frequency of the pulse function in CC mode. (p.116)

**CURR:PULS:HIGH**

For the pulse function in CC mode, sets the high level current. (p.116)

**CURR:PULS:LOW**

For the pulse function in CC mode, sets the low level current. (p.117)

**CURR:RESP**

Sets the response in the CC mode. (p.117)

**CURR:SEAM**

Sets the current for seamless operation. (p.118)

**CURR:SINE:AMPL**

Sets the amplitude of the CC mode sine function (peak-to-peak value). (p.118)

**CURR:SINE:FREQ**

Sets the frequency of the sine function in CC mode. (p.119)

**CURR:SINE:OFFS**

Sets the correction value of the sine function waveform in CC mode. (p.119)

**CURR:SLEW**

Sets the slew rate in the CC mode. (p.120)

**SOURce:POWer Command****POW**

Sets the power on the source side in the CP mode. (p.121)

**POW:NEG**

Sets the power in absolute value on the sink side in the CP mode. (p.121)

**POW:FUNC:MODE**

Sets the output function for CP mode. (p.122)

**POW:PROT**

Sets the threshold power for the overpower protection (OPP) on the source side. (p.122)

**POW:NEG:PROT**

Sets the threshold power in absolute value for the over-power protection (OPP) on the sink side. (p.123)

**POW:SEAM**

Sets the power for seamless operation. (p.123)

**SOURce:RESistance Command****RES:IR**

Sets the internal resistance value. (p.124)

**SOURce:VOLTage Command****VOLT**

Sets the voltage in CV mode. (p.125)

**VOLT:FUNC:MODE**

Sets the output function for CV mode. (p.126)

**VOLT:IV:CAT?**

Queries voltage and current for all point indexes of the I-V characteristic in CV mode. (p.126)

**VOLT:IV:CLE**

Returns the I-V characteristics in CV mode to the factory default setting. (p.127)

**VOLT:IV:COUN**

Sets the number of data points of I-V characteristics in CV mode. (p.127)

**VOLT:IV:DATA**

Sets the entire I-V characteristics in CV mode in the binary block data format. (p.128)

**VOLT:IV:MAP<n>**

Sets the voltage and current for the specified parts (point index) of the I-V characteristics in CV mode. (p.130)

**VOLT:IV:MAP<n>:DEL**

Deletes the voltage and current for the specified parts (point index) of the I-V characteristics in CV mode. (p.130)

**VOLT:IV:MAP<n>:INS**

Inserts a point index at the specified section of the I-V characteristics in CV mode. (p.131)

**VOLT:PROT**

Sets the voltage of overvoltage protection (OVP). (p.131)

**VOLT:PROT:LOW**

Sets the voltage of undervoltage protection (UVP). (p.132)

**VOLT:PROT:LOW:STAT**

Enables/disables undervoltage protection (UVP). (p.132)

**VOLT:PULS:DCYC**

Sets the duty cycle of the pulse function in CV mode. (p.133)

**VOLT:PULS:FREQ**

Sets the frequency of the pulse function in CV mode. (p.133)

**VOLT:PULS:HIGH**

For the pulse function in CV mode, sets the high level current. (p.134)

**VOLT:PULS:LOW**

For the pulse function in CV mode, sets the low level current. (p.134)

**VOLT:RESP**

Sets the response in the CV mode. (p.135)

**VOLT:SINE:AMPL**

Sets the amplitude of the CV mode sine function (peak-to-peak value). (p.135)

**VOLT:SINE:FREQ**

Sets the frequency of the sine function in CV mode. (p.136)

**VOLT:SINE:OFFS**

Sets the correction value of the sine function waveform in CV mode. (p.136)

**VOLT:SLEW**

Sets the voltage slew rate in the CV mode. (p.137)

**TRIGger Command****TRIG:ACQ**

Sends a software trigger to start measurement. (p.138)

**TRIG:ACQ:COUN**

Sets the number of times measured values are to be recorded. (p.138)

**TRIG:ACQ:DEL**

Set the delay time until the measurement is started after the measurement trigger is applied. (p.139)

**TRIG:ACQ:INT:STAT**

Sets whether to measure at intervals when the trigger count is 2 or higher. (p.139)

**TRIG:ACQ:INT:TIME**

Sets the measurement interval time when TRIG:ACQ:INT:STAT is set to ON. (p.140)

**TRIG:ACQ:MSYN**

Sends a measurement sync signal. (p.140)

**TRIG:ACQ:SOUR**

Clears the measurement trigger wait state and sets the trigger source for starting measurements. (p.141)

**TRIG:TRAN**

Sends a software trigger of sequence. (p.141)

**TRIG:TRAN:EXEC?**

Queries the execution state of sequence function. (p.142)

**TRIG:TRAN:MSYN**

Sends a sequence sync signal.s (p.142)

**TRIG:TRAN:PAUS**

Pauses a sequence being executed. (p.142)

**TRIG:TRAN:RES**

Resumes the paused sequence from the point at which it was paused. (p.143)

**TRIG:TRAN:SOUR**

Sets the conditions for starting the sequence by releasing the trigger wait of the sequence (trigger source) for the program selected in PROG:NAME. (p.143)

## SYSTem Command

**SYST:BEEP**

Sets the buzzer sound ON/OFF in a batch when operation is invalid, when a protection function is activated, or when an SCPI error occurs. (p.144)

**SYST:BEEP:KEY**

Sets the buzzer sound ON/OFF in case of invalid operation. (p.144)

**SYST:BEEP:PROT**

Turns ON/OFF the buzzer that sounds when a protection function is activated. (p.145)

**SYST:BEEP:SCPI**

Turns ON/OFF the buzzer that sounds when an SCPI error occurs. (p.145)

**SYST:COMM:RLST**

Enables/disables the panel operation and remote operation of PXB series. (p.146)

**SYST:DATE**

Sets the date for the clock. (p.147)

**SYST:ERR?**

Reads the oldest error information or event information from the error queue. (p.147)

**SYST:ERR:COUN?**

Queries the number of unread errors in the error queue. (p.148)

**SYST:KLOC**

Enables/disables panel control lock. (p.148)

**SYST:KLOC:LEV**

Sets the panel control lock level. (p.149)

**SYST:MSYN?**

Queries whether synchronization connection is enabled or disabled. (p.149)

**SYST:PARA:UNIT:COUN?**

Queries the number of parallel operation units including the master unit. (p.150)

**SYST:PON**

Sets the panel setting state when the POWER switch is turned on. (p.150)

**SYST:PON:REC**

Specifies the number of setup memory to apply when SYST:PON is set to RCL. (p.150)

**SYST:PROT:LINE:VOLT**

Sets the voltage of line overvoltage protection (LOVP). (p.151)

**SYST:RSEN**

Sets remote sensing function on/off. (p.151)

**SYST:TIME**

Sets the time for the clock. (p.152)

**SYST:TIME:ADJ**

Automatically synchronizes the system clock using the NTP server on the network. (p.152)

**SYST:TZON**

Sets the time zone of the system clock. (p.152)

**SYST:TZON:CAT?**

Queries the time zone IDs that can be used. (p.153)

**SYST:VERS?**

Queries the version of the SCPI specifications that this product complies with. (p.153)

## STATus Command

**STAT:OPER?**

Queries the event of the OPERation status register. (p.159)

**STAT:OPER:COND?**

Queries the condition of the OPERation status register. (p.159)

**STAT:OPER:ENAB**

Sets the enable register of the OPERation status register. (p.160)

**STAT:OPER:NTR**

Sets the negative transition filter of the OPERation status register. (p.160)

**STAT:OPER:PTR**

Sets the positive transition filter of the OPERation status register. (p.160)

**STAT:OPER:INST?**

Queries the event of the OPERation:INSTrument subregister. (p.161)

**STAT:OPER:INST:COND?**

Queries the condition of the OPERation:INSTrument subregister. (p.161)

**STAT:OPER:INST:ENAB**

Sets the enable register of the OPERation:INSTrument subregister. (p.162)

**STAT:OPER:INST:NTR**

Sets the negative transition filter of the OPERation:INSTrument subregister. (p.162)

**STAT:OPER:INST:PTR**

Sets the positive transition filter of the OPERation:INSTrument subregister. (p.162)

**STAT:OPER:INST:ISUM<n>?**

Queries the event of the OPERation:INSTrument:ISUMmary<n> subregister. (p.163)

**STAT:OPER:INST:ISUM<n>:COND?**

Queries the condition of the OPERation:INSTrument:ISUMmary<n> subregister. (p.164)

**STAT:OPER:INST:ISUM<n>:ENAB**

Sets the enable register of the OPERation:INSTrument:ISUMmary<n> subregister. (p.164)

**STAT:OPER:INST:ISUM<n>:NTR**

Sets the negative transition filter of the OPERation:INSTrument:ISUMmary<n> subregister. (p.164)

**STAT:OPER:INST:ISUM<n>:PTR**

Sets the positive transition filter of the OPERation:INSTrument subregister. (p.165)

**STAT:QUES?**

Queries the event of the QUESTionable status register. (p.166)

**STAT:QUES:COND?**

Queries the condition of the QUESTionable status register. (p.166)

**STAT:QUES:ENAB**

Sets the enable register of the QUESTionable status register. (p.167)

**STAT:QUES:NTR**

Sets the negative transition filter of the QUESTionable status register. (p.167)

**STAT:QUES:PTR**

Sets the positive transition filter of the QUESTionable status register. (p.167)

**STAT:QUES:INST?**

Queries the event of the QUESTionable:INSTrument subregister. (p.168)

**STAT:QUES:INST:COND?**

Queries the condition of the QUESTionable:INSTrument subregister. (p.168)

**STAT:QUES:INST:ENAB**

Sets the enable register of the QUESTionable:INSTrument subregister. (p.169)

**STAT:QUES:INST:NTR**

Sets the negative transition filter of the QUESTionable:INSTrument subregister. (p.169)

**STAT:QUES:INST:PTR**

Sets the positive transition filter of the QUESTionable:INSTrument subregister. (p.169)

**STAT:QUES:INST:ISUM<n>?**

Queries the event of the QUESTionable:INSTrument:ISUMmary<n> subregister. (p.170)

**STAT:QUES:INST:ISUM<n>:COND?**

Queries the condition of the QUESTionable:INSTrument:ISUMmary<n> subregister. (p.171)

**STAT:QUES:INST:ISUM<n>:ENAB**

Sets the enable register of the QUESTionable:INSTrument:ISUMmary<n> subregister. (p.171)

**STAT:QUES:INST:ISUM<n>:NTR**

Sets the negative transition filter of the QUESTIONable:INSTrument:ISUMmary<n> subregister. (p.171)

**STAT:QUES:INST:ISUM<n>:PTR**

Sets the positive transition filter of the QUESTIONable:INSTrument:ISUMmary<n> subregister. (p.172)

**STAT:PRES**

Resets the ENABLE, PTRansition, and NTRansition filter registers of all status registers (including sub registers) to their default values. (p.172)

# Introduction

The communication interface manual explains the settings that are used to control PXB series remotely through the following interfaces and the available commands.

- RS232C interface
- USB interface
- LAN interface

For the safety precautions, installation, operation, and specifications of this product, read the accompanying PXB series user's manual.

## About This Manual

### Intended readers

This manual is written for readers with sufficient basic knowledge of how to control measuring instruments using a PC. Familiarize yourself with the syntax of the SCPI commands that are used with this product before you use them.

### Trademarks

Microsoft Windows is a trademark of Microsoft Corporation in the United States and/or other countries.

All other company and product names used in this manual are trademarks or registered trademarks of their respective owners.

### System versions that this manual covers

This manual applies to the products with the firmware of system version 3.2X.

### Measuring instrument interface standards

This product complies with the following standards.

- IEEE Std 488.2-1992 IEEE Standard Codes, Formats, Protocols, and Common Commands For Use With IEEE Std 488.1-1987
- Standard Commands for Programmable Instruments (SCPI) version 1999.0
- Universal Serial Bus Specification Rev 2.0
- Universal Serial Bus Test and Measurement Class Specification (USBTMC) Rev 1.0
- Universal Serial Bus Test and Measurement Class, Subclass USB488 Specification (USBTMC-USB488) Rev 1.0
- TCP/IP Instrument Protocol Specification VXI-11 Rev 1.0 1995
- TCP/IP-IEEE488.2 Interface Specification VXI-11.3 Draft 0.3 1995
- 1.5 LXI Device Specification 2016
- LXI HiSLIP Extended Function Rev 1.01
- IVI-6.1 IVI High-Speed LAN Instrument Protocol (HiSLIP) Revision 2.0
- VPP-4.3 The VISA Library 2015 Rev 5.5

### Copyright



The contents of this manual may not be reproduced, in whole or in part, without the prior consent of the copyright holder.

The specifications of this product and the contents of this manual are subject to change without prior notice.

©2023 Kikusui Electronics Corporation

# States of Panel Operation and Remote Operation

The panel and the remote operations fall into four states: LOCAL, REMote, RWLock, and LWLock. You can set LOCAL, REMote, and RWLock using SYST:COMM:RLST (p. 146). In the table below, the operations with the checks in the corresponding cells are enabled.

Settings	Panel operation	Remote operation	Notes
LOCAL	✓	✓	Default
REMOte	–	✓	The Remote icon (  ) appears in the top right of the display. Pressing and holding the icon will change the state to LOCAL. <sup>1</sup>
RWLock	–	✓	The RWLS icon (  ) appears in the top right of the display. Pressing and holding the icon does not change the state to LOCAL.
LWLock	–	–	The LWLS icon (  ) appears in the top right of the display. Pressing and holding the icon does not change the state to LOCAL. Send an arbitrary command to return to RWLock. The followings are the possible causes to generate LWLock. <ul style="list-style-type: none"> <li>• The USB cable connection signal stopped during the RWLock status when using the USB interface.</li> <li>• Sent a Go To Local command by VISA during the RWLock status.</li> </ul>

1. If Web browser interface display and command transmission through a USB connection are performed simultaneously, pressing and holding the icon does not change the state to LOCAL. The state changes to LOCAL when SYST:COMM:RLST is set to LOCAL, the browser displaying the Web browser interface is closed, the USB cable is disconnected, or the power supply of the PXB series is turned off and then back on.

# Setup

## Installing a VISA Library

VISA (Virtual Instrument Software Architecture) library was developed by the IVI Foundation. It is the standard specification for measuring instrument connection software.

### Need for VISA library

- To use the VISA library (VISA COM) with the I/O library, the VISA library must be installed on the controller (Windows).
- If you are controlling the instrument using RS232C or LAN communication from a PLC or microcomputer board, a VISA library is not required.

### Installing a VISA library

You have to install one of the following VISA libraries (driver software that is implemented according to the VISA specifications).

- NI-VISA by National Instruments Corporation (Ver. 19.0 or later)
- Keysight VISA (Keysight IO Libraries Suite 18.1 or later) by Keysight Technologies
- KI-VISA (Ver. 5.5 or later)

---

### NOTE

- Do not install multiple VISA libraries on the same PC. Doing so may cause errors.
  - If NI-VISA or Keysight VISA is already installed on your PC, you do not need to install KI-VISA.
- 

Kikusui original KI-VISA that supports version 5.0 of the IVI VISA specification is available. You can also download from the Kikusui Electronics Corporation website (<https://global.kikusui.co.jp/downloads/>).

## Setting Up the Interface

The product is standard equipped with RS232C, USB, and LAN interfaces. In addition to a PC, remote control is possible from a PLC, microcomputer board, or the like that support non-procedural communication.

There is no need to switch interfaces. All interfaces can be used simultaneously.

---

### WARNING

**If the remote control via digital communication fails, this product will operate unexpectedly, resulting in electric shock, fire, or property damage to the device under test. When controlling this product from a remote location, take safety measures such as using a communication monitoring (WATCHDOG) timer.**

---

# RS232C

## RS232C connection

The RS232C port on this product side is D-sub 9-pin. Check that this product and your PC are off, and then connect them.

For the RS232C cable, use a D-sub, 9-pin, female-to-female crossover cable.

The figure below shows the port pinout.

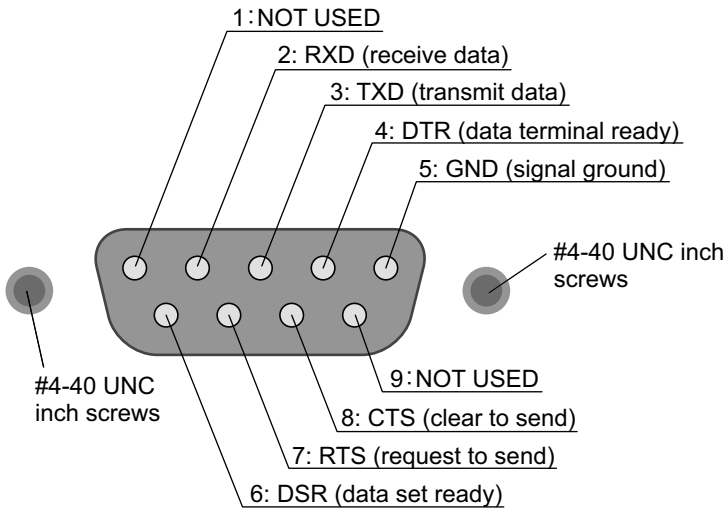

RS232C pinout (viewed from the product's rear panel)

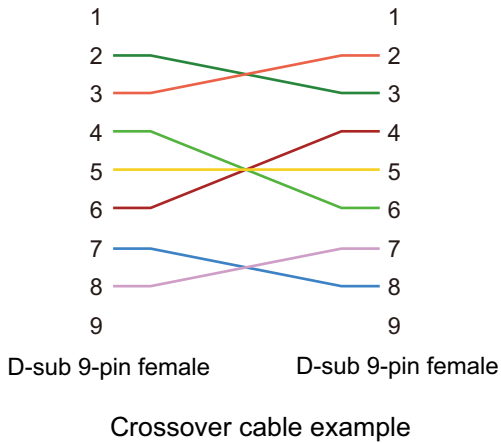

## Protocol

The RS232C protocol is shown in the following table.

The underlined value is the factory default value.

Item	Set value
Bitrate: data rate (bps)	1200, 2400, 4800, 9600, <u>19200</u> , 38400, 57600, 115200
Data Bits: Data length	8 bits (fixed)
Stop Bits	1 bit (fixed)
Parity	None (fixed)
Flow Control	<u>No</u> , CTS-RTS

## RS232C settings

For details, see the user's manual.

- 1** Press **System > Communication** on the homepage.
- 2** Press **RS232C**.
- 3** Press **Change values settings**.  
Press the input field to change the selected item, entered text/number, or the existence of checking according to the set item.
- 4** Press **Set**.  
A confirmation screen appears.
- 5** Press **OK**.  
This completes the setting.

## Break signal

The break signal is used as a substitute for the IEEE488.1 dcl/sdc (Device Clear, Selected Device Clear) message.

## USB

---

To use the USB interface to control this product, a device driver that supports the USB Test & Measurement class (USBTMC) must be installed on the controller. The USBTMC driver is installed automatically by the VISA library.

### USB connection

Turn off the PC and PXB series.

Connect the PC to the USB connector on the rear panel of PXB series with the USB cable, then turn on the PC and PXB series.

### Service request

This product is equipped with service request and serial polling functions.

### USB specifications

Hardware: Standard Type-B socket compliant with USB 2.0 specifications, Transfer rate: 480 Mbps (High Speed)

Program message terminator: LF or EOM for receiving, LF + EOM for sending

Device class: Complies with the USBTMC USB488 subclass specification

VID (vendor ID): 0x0B3E

PID (product ID): 0x105B

## LAN

---

### WARNING

**Possible damage to the equipment and electric shock. The LAN interface can be accessed from anywhere on the network that the product is connected to. Change the security settings if necessary. The security settings that you can apply are: password protection and IP address access control.**

---

To control this product via the VXI-11/HiSlip protocol, an applicable middleware is necessary. When you install the VISA library, the middleware will be installed automatically. To control via the SCPI-RAW/SCPI-Telnet protocol, no middleware is necessary.

For information on topics such as connecting to your corporate LAN, your IP address, your host name, and security, contact your network administrator.

## LAN connection

Use a standard LAN cable (category 5 or later) to connect this product to a network hub or router.

## LAN settings

You can assign an IP address by selecting AUTO (automatically assigned dynamic IP address) or MANUAL (static IP address) from 'IP Source'. Normally, select 'AUTO' (factory default setting).

In the case of automatic assignment of IP address, we recommend using the DHCP server function using a router as far as possible. If the DHCP server function is not used, it takes about 60 seconds until determination that address assignment with DHCP has failed. Then, an address 169.254.xxx.xxx is assigned by link local address (Auto-IP).

To set the IP address manually, set 'IP Source' to 'MANUAL', and then set the IP address. For details, see the user's manual.

- 1 Press System > Communication on the homepage.**  
You can check the communication settings. Swipe to the left to view the page not displayed.
- 2 Press Edit.**
- 3 Change values settings.**  
Press the input field to change the selected item, entered text/number, or the existence of checking according to the set item.
- 4 Press Apply.**  
A confirmation screen appears.
- 5 Press OK.**  
This completes the setting.

## Service request

This product is equipped with service request and serial polling functions.

## LAN specifications

### Hardware

Complies with IEEE 802.3 100BASE-TX/10BASE-T Ethernet, LXI Version 1.5 Specifications 2016

### Communication protocol

SCPI-RAW, SCPI-Telnet, HiSLIP, VXI-11

### Program message terminator

HiSLIP: LF or END during reception, LF + END during transmission.

SCPI-RAW: LF during reception, LF during transmission

## Returning LAN interface to the factory default settings

You can reset the LAN interface settings to the factory default from the system settings.

The factory default settings are shown below.

Item	Default value
IP Address assignment method	AUTO
IPv4 Address	-
IPv4 Subnet Mask	-
IPv4 Default Gateway	-
IPv4 DNS Server1	-
IPv4 DNS Server2	-
Hostname	Model name and serial number
Description	KIKUSUI <name> Bidirectional DC Power Supply -<serial> <name>: model name, <serial>: serial number
Domain	-
Dynamic DNS	Enable
mDNS	Enable

- 1** Press **System > Communication** on the homepage.
- 2** Press **Edit > Default**.  
A confirmation screen appears.
- 3** Press **OK**.  
The LAN interface settings are returned to their factory default settings.

## Accessing and Operating the Product from a Web Browser

If you connect a PC to the PXB series using the LAN interface, you can control the PXB series and acquire the information from the PC's browser.

### Applicable browser

Microsoft Edge, Google Chrome, Safari, Mozilla FireFox, and Opera

Use the latest version of the browser.

## Access the Web browser interface

### NOTE

- If you connect to the PXB series from the Web browser interface, a HIGH alarm (ERRS) may occur on the side of PXB series main unit. When an alarm occurs, turn off the power supply to the PXB series after checking the following points, and then turn it on again.
  - Adjust the clock of the PXB series main unit to match the clock of the PC that is displaying the Web browser interface.
  - The alarm occurs when the line or power supply is disconnected and reconnected to the PC that is displaying the Web browser interface. Check the condition of the PC.
- To check the latest state of settings, refresh (reload) the page on your browser.
- If the Web browser interface is displayed in a disorganized way, refresh (reload) the page in your browser.

### Enter the URL in the address bar of the browser

The IP address of the PXB series followed by http:// is the URL of the Web browser interface. You can check the IP address on the LAN and Network screen (press SYSTEM and then Communication).

Example) When the IP address is 169.254.7.8

http://169.254.7.8

### Search by VISA Application

If a VISA library is in use, the Web browser interface will open if you search for VXI-11 measuring instrument with the applications provided by each VISA vendor (National Instruments NI-MAX, Keysight Connection Expert, Kikusui KI-VISA Instrument Explorer, or the like) and click on the web link from the search results.

### Input the password

In the factory default conditions, the Web browser interface is protected by a password. When the password input screen is displayed, input the factory default setting password "kikusui." You can change the password on the Security page (p.39).

## Screen configuration for the Web browser interface

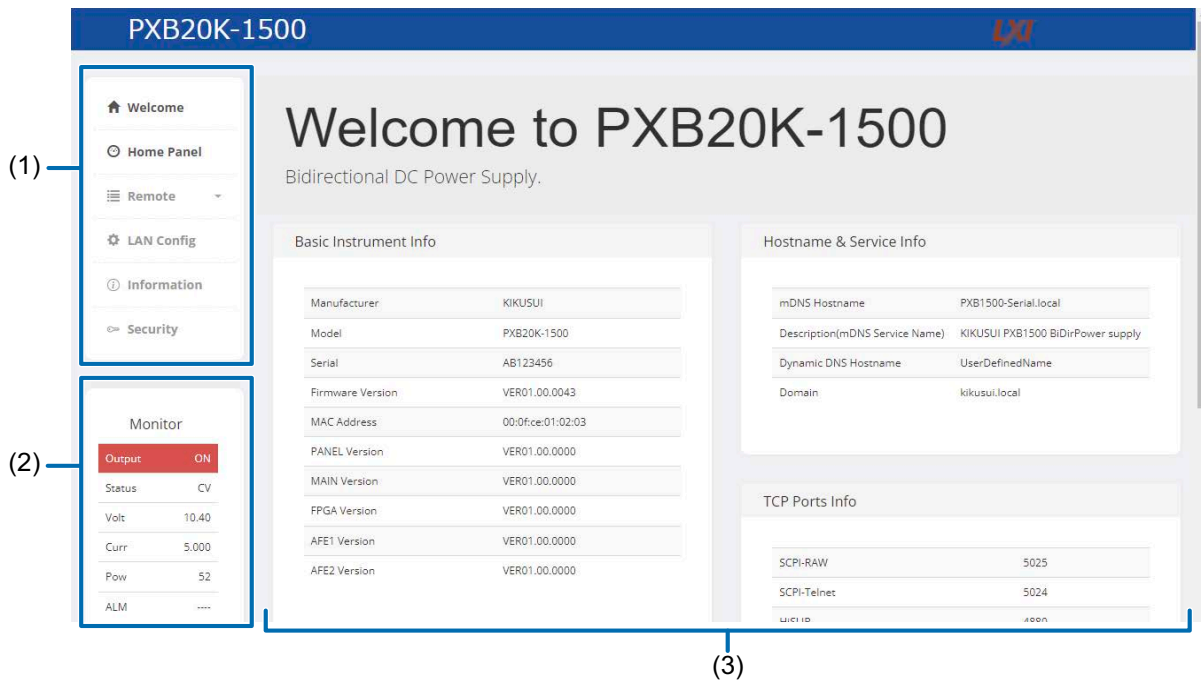

### (1) Menu

- Welcome: Basic information on the PXB series is displayed. (p.27)
- Home Panel: The functions most frequently used are displayed. (p.28)
- Remote: You can control the PXB series remotely from the browser. (p.29)
- LAN Config: Network setup items can be displayed and changed. (p.37)
- Information: The license information of the open-source software is displayed. (p.38)
- Security: You can set and change the password for the Web browser interface. (p.39)
- VMCB Link: The domain number and channel list of Multichannel are displayed. (p.40)

### (2) Monitor

Displays the status of the PXB series.

### (3) Information display area

Displays information depending on the menu selected.

## Welcome page

This is the first page that is displayed when you connect to the Web browser interface.

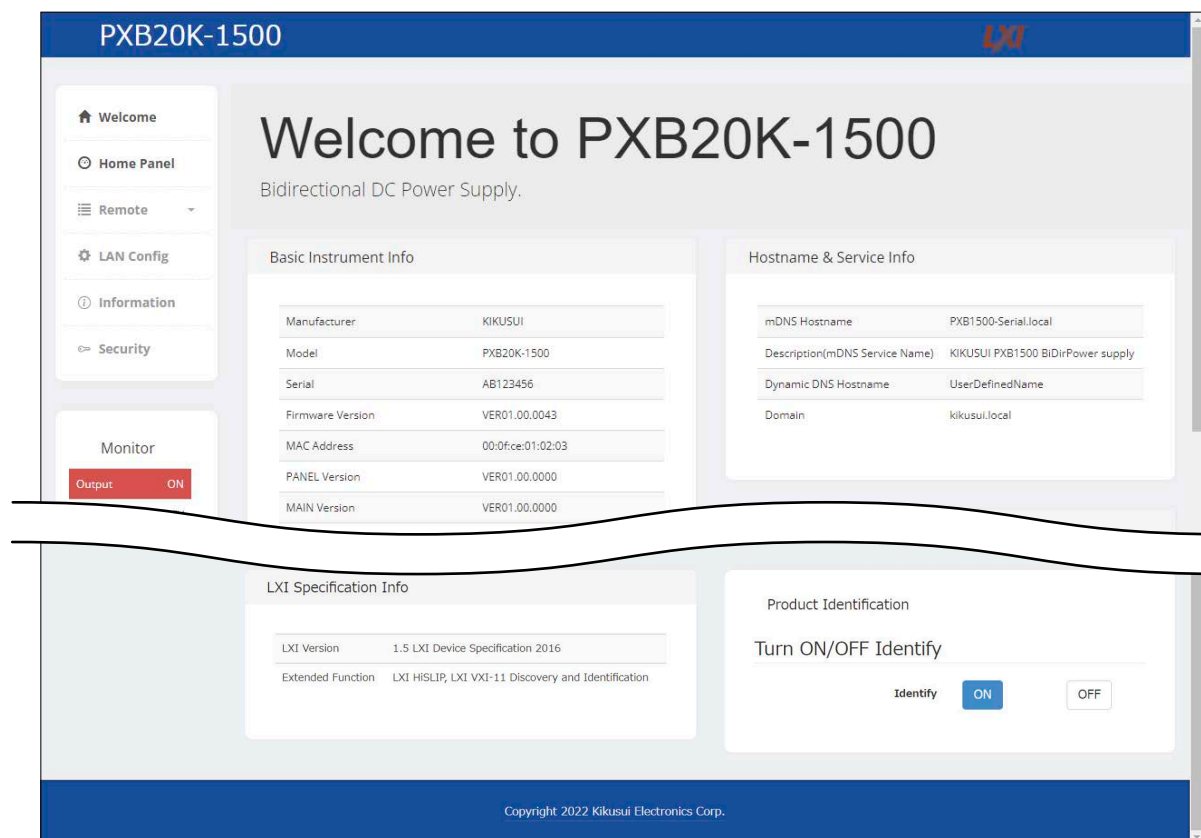

You can display the equipment information, network information, and VISA resources (I/O resources) information, and also check the connected PXB series.

### Turn ON/OFF Identify

If you turn ON Identify, LAN status icon of the PXB series connected will blink.

## Home Panel page

The functions most frequently used are displayed.

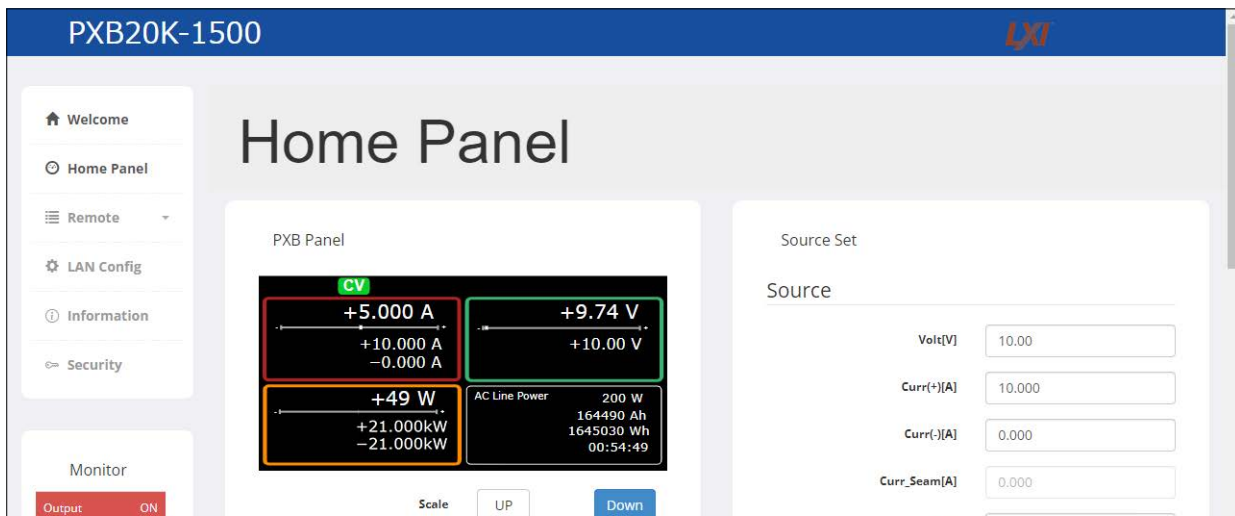

### PXB Panel

The settings and the measured values that are the same as those on the PXB series are displayed.

The operation mode icon (**CV** **CC** **CP**) displayed at the top of the screen will blink until the output reaches 0 V after the operation to turn off the output.

When you click UP/Down, the display will zoom in or out. Refreshing (reloading) the page in the browser will result in a Down display.

### Source Set

Sets the output value of the PXB series.

### Output Set

Turns ON/OFF the output value of the PXB series.

### Synchronize Operation

Enable Msync: Enables or disables synchronization function.

Msync Output: Synchronizes output ON/OFF.

### Sequence Status

Displays sequence execution state (Status), program name (Program), step numbers being executed (Current Step), and the number of times the loop is being executed at present (Current Loop).

### Sequence Operation

Performs sequence execution (Run), stop (Stop), pause (Pause), resume (Resume), and sends synchronization triggers (Msync).

### Select Program to Run

Sets the program chain. If the program is moved from BASE to SELECTED, it will be registered in the chain. You can use program click, drag & drop, or click on the arrow icon to move it. In SELECTED, you can change the order of programs by drag & drop.

To update a program display, press Update Program Data. To unlock a chain, press Clear.

## Remote Control page

### **⚠ WARNING**

If a network problem occurs, an unexpected dangerous voltage may occur that may cause electric shock, fire, physical damage to the DUT, and so on. If you are going to remotely control the PXB series from a distance, install a Web camera or take other measures to monitor the status.

You can control the PXB series remotely from the browser. Selects the function to be controlled from the menu on the left.

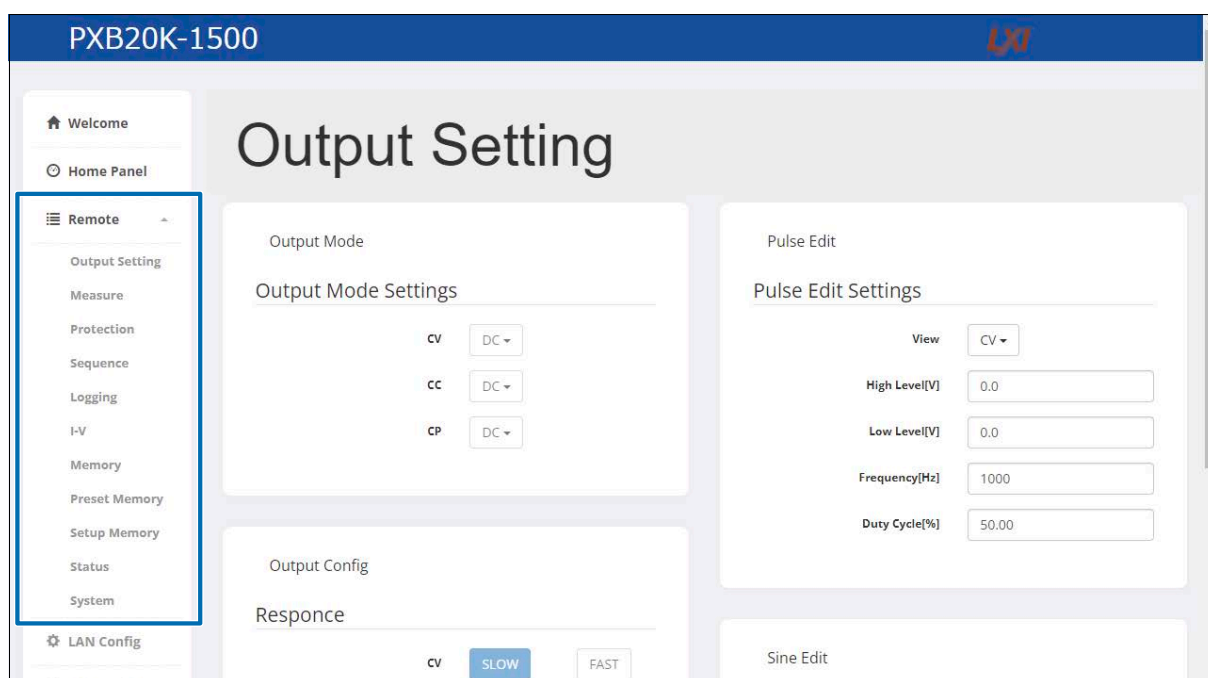

Menu	Available operations
Output Setting	Setting response, setting slew rate, setting impedance at the time of output off, setting output mode, setting internal resistance function, setting pulse function, and setting sine function. (p.30)
Measure	Setting measured trigger, setting recording interval of measured value, setting integrated trigger, and setting remote sensing. (p.31)
Protection	Set the protection function. (p.31)
Sequence	Checking sequence status, execution and cancel of sequence, synchronization of sequence execution, setting program chain, selection of program, checking program settings, checking step settings, changing program name, overwriting program, new creating and deleting program, and exporting & importing program. (p.31)
Logging	Graph display of measured value, execution and cancel of measurement, and exporting measured value. (p.34)
I-V	Setting operation mode, graph display and list display of I-V characteristic, saving & clearing I-V characteristic, and exporting & importing I-V characteristic. (p.34)
Memory	Setting at the time of startup, output state at the time of startup, and resetting the settings. (p.35)
Preset Memory	Check of preset memory and saving and recalling of memory. (p.35)
Setup Memory	Checking setup memory, saving/recalling memory, and exporting/importing memory. (p.35)
Status	Display of alarms, clearance of Low alarms, and display and clearance of SCPI errors. (p.36)
System	Input/output range settings for external control, function settings for general-purpose digital input/output, enabling/disabling of digital input/output, and buzzer sound settings. (p.36)

## Output Setting

Menu related to the output.

### Output Mode

Set the output mode according to each operation mode.

### Output Config

Response: Sets the response for each operation mode.

Slew Rate: Set the slew rate for each operation mode.

Priority/Impedance: Sets the prioritized operation mode when the output is on and the impedance when the output is OFF.

### Pulse Edit

Sets pulse waveform in CV mode and CC mode, respectively.

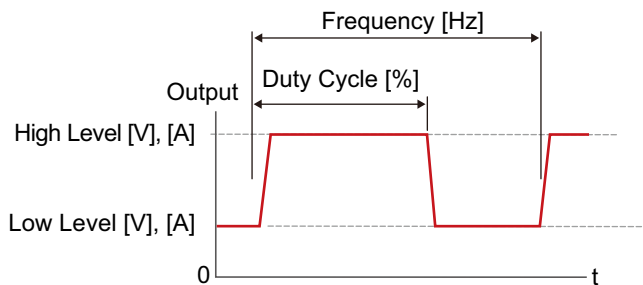

### Sine Edit

Sets sine waveform in CV mode and CC mode, respectively.

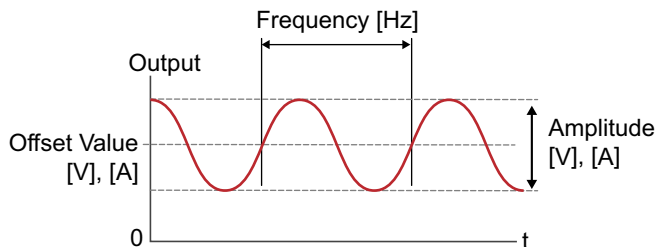

### IR Edit

Sets the resistance and offset voltage for the internal resistance function.

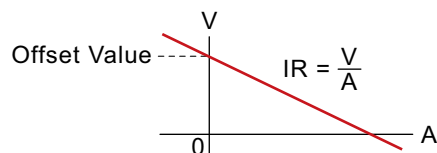

## Measure

Menu related to measurement.

**Acquire Trigger:** Set the conditions for starting to record measured values (trigger source), the number of times measured values are recorded, the delay time from when the trigger is applied to when the measurement starts, and the recording time per measurement.

**Acquire Interval:** Sets the recording interval for measured values.

**Integral:** Sets the conditions for starting/ending integration and the conditions for resetting.

**RMT Sensing:** Enables or disables remote sensing.

## Protection

Menu related to protection function.

**Voltage:** Sets the overvoltage protection (OVP) value, the constant voltage protection (UVP) value, and enabling/disabling of UVP.

**Current:** Sets overcurrent protection (OCP (+), OCP (-)) value and the delay time (OCP Delay) from detection of a current at or more the OCP value until the OCP trip point.

**Power:** Sets the overpower protection (OPP (+) and OPP (-)) value.

**Line:** Sets the line overvoltage protection (Line OVP) value.

**Communication:** Sets communication error protection (WDog) value and enables or disables WDog.

**Sensing:** Enables or disables incorrect sensing connection detection (SENS Error).

## Sequence

Menu related to sequence.

On this page, you cannot edit the program settings and step settings. Create a program with Sequence Create/Delete, and then download a CSV file of the program with File Download to edit the contents. Upload the edited CSV file to the Web browser interface with File Upload and overwrite and save the PXB series main unit with Sequence Overwrite.

### Sequence Status

Displays sequence execution state (Status), program name (Program), step numbers being executed (Current Step), and the number of times the loop is being executed at present (Current Loop) .

### Sequence Operation

Performs sequence start (Run), stop (Stop), pause (Pause), and resume (Resume). Pressing Msync resumes the sequence in trigger wait state on the PXB series in synchronization simultaneously.

### Select Program to Run

Sets the program chain. If the program is moved from BASE to SELECTED, it will be registered in the chain. You can use program click, drag & drop, or click on the arrow icon to move it. In SELECTED, you can change the order of programs by drag & drop.

To update a program display, press Update Program Data. To unlock a chain, press Clear.

### Program List

Selects programs.

### Program Data

Displays the list of settings for the program selected in Program List.

### Step Data

Displays the list of program steps selected in the Program List and the settings for each step. You cannot change the settings.

The number of steps displayed can be selected from 10, 50, 100, or 500 from the drop-down menu.

## Sequence Overwrite

Overwrite the PXB series with the program settings on the Web browser interface.

**New Name:** Enter the program name in the case that you wish to change the program name when overwriting. You can enter the following characters: Alphabet characters A-Za-z, numbers 0-9, dot (.), comma (,), parentheses (), brackets [], braces </>, and (&), dollar (\$), hash (#), caret (^), percent (%), equal (=), hyphen (-), plus (+), underscore (\_), space ( ), case-sensitive, up to 32 characters.

**Overwrite:** Select the program name to overwrite. In the case of changing a program name, change it with New Name. When you press Overwrite, the program is overwritten.

---

### NOTE

The more steps there are, the more time it will take to overwrite the program. Do not move to other screens while the browser displays "Saving...". Data may not be overwritten successfully.

---

## Sequence Create/Delete

**Create New:** When you input any program name and press Create New, a new program is created. You can enter the following characters: Alphabet characters A-Za-z, numbers 0-9, dot (.), comma (,), parentheses (), brackets [], braces </>, and (&), dollar (\$), hash (#), caret (^), percent (%), equal (=), hyphen (-), plus (+), underscore (\_), space ( ), case-sensitive, up to 32 characters.

**Delete:** When you select a program name and press Delete, the program is deleted.

## File Upload

Uploads a CSV file of the program. Uploaded programs are saved on the Web browser interface. To save the data in the PXB series main unit, further overwrite and save the data in the PXB series with Sequence Overwrite.

## File Download

Downloads the program files in CSV format. You can edit the downloaded CSV.

The CSV format is as follows:

- Column A

Item	Description	Applicable command
IDN	Displays the response of *IDN? Do not change.	—
RATED_POWER	Rated power. Do not change.	—
RATED_VOLT	Rated voltage. Do not change.	—
LOOP	Sets the repetition count in number. When repeated infinitely: 0, INF or INFINITY	PROG:LOOP
CC_SEAM	Sets the CC output mode. Set to SEAM: 1, TRUE, EN, ENABLE, DSE or DSEAMLESS Set to DC: 0, FALSE, DIS, DISABLE, or DC	PROG:CURR:FUNC:MODE
CP_SEAM	Sets the CP output mode. Set to SEAM: 1, TRUE, EN, ENABLE, DSE, or DSEAMLESS Set to DC: 0, FALSE, DIS, DISABLE, or DC	PROG:POW:FUNC:MODE
WTRIG	Trigger wait settings. IMM (IMMEDIATE), BUS, EXT (EXTERNAL), or MSYN (MSYNC)	TRIG:TRAN:SOUR

- STEP line

Item	Description	Applicable command
Output ON/OFF	Sets the output to on or off. Set to ON: 1, TRUE, EN (ENABLE), or ON Set to OFF: 0, FALSE, DIS (DISABLE), or OFF	PROG:STEP<n>:OUTP
Ramp	Sets how the value transition is performed. IMM (IMMEDIATE), CV, CC, or CP	PROG:STEP<n>:RAMP
Dwell	Sets the step execution time in number. Uses the format hhhh:mm:ss[.ff] to describe hours, minutes, seconds, and milliseconds. Milliseconds can be omitted. Example: 0:12:34.567 in the case of 12 minutes 34.567 seconds Example: 1:23:45 or 0001:23:45.000 in the case of 1 hour, 23 minutes and 45 seconds	PROG:STEP<n>:DWEL
Step Output Mode	Sets the output mode for the step. DC, IR, CVS (CVSINE) or CCS (CCSINE)	PROG:STEP<n>:FUNC:MODE
Output Mode Transition ON/OFF	Sets whether to perform transition to the next step automatically when the operation mode changes during step. Perform transitions: 1, TRUE, EN, ENABLE, or ON Not perform transition: 0, FALSE, DIS, DISABLE, or OFF	PROG:STEP<n>:OUTP:MODE:TRAN
CV[V] CC(+)[A] CC(-)[A] CP(+)[kW] CP(-)[kW]	Sets each output value in number.	PROG:STEP<n>:VOLT PROG:STEP<n>:CURR PROG:STEP<n>:CURR:NEG PROG:STEP<n>:POW PROG:STEP<n>:POW:NEG
CC Seamless[A] CP Seamless[kW]	Sets the current for seamless operation in number when CC_SEAM is set to SEAM. Sets the power for seamless operation in number when CP_SEAM is set to SEAM.	PROG:STEP<n>:CURR:SEAM PROG:STEP<n>:POW:SEAM

Item	Description	Applicable command
IR[OHM]	Sets each resistance in number.	PROG:STEP<n>:RES:IR
Wait Trigger	Sets trigger wait. IMM (IMMEDIATE), BUS, EXTERNAL or MSYNC	PROG:STEP<n>:TRIG:WAIT
Trigger Generate	Sets trigger output. NONE, DC, or PULS (PULSE)	PROG:STEP<n>:TRIG:GEN

## Logging

Menu related to measured value recording.

### Logging Volt, Logging Curr, Logging Power

Displays recorded measured values in a graph.

### Graph View

Display/hide the graphs of integrated current and integrated power.

### Measure Operation

Measure Status :Displays the measurement status. Stop is displayed during stopping, Measuring is displayed during running, and Free Run is displayed during Free Run Mode.

Free Run Mode: When you press Initiate, the measurement repeats indefinitely. To cancel measurement, press Abort or reload the web page.

Acquire Key: Starts or cancels measurement. Pressing Msync resumes measurement in trigger wait state on the PXB series in synchronization simultaneously.

Integral Key: Starts, stops, and resets integration.

### File Download

Downloads measurement data and integrated data in CSV format. Outputs in the order of voltage, current, power, elapsed time, integrated capacity, and integrated power from the left side of the column.

## I-V

Sets the I-V characteristic function.

### I-V Mode

Sets the operation mode (CV/CC).

### I-V Chart

Displays I-V characteristics in a graph.

### I-V List

Displays I-V characteristic in a list.

### I-V Operation

Save: Overwrites the PXB series with the I-V characteristic data uploaded by File Upload.

All Clear: Initializes the I-V characteristic data displayed on the Web browser interface.

Cancel: Reacquire the I-V characteristic data saved in the PXB series main unit.

## File Upload

Uploads a CSV file of the I-V characteristic. To reflect I-V characteristics in the PXB series, save it with I-V Operation after uploading.

## File Download

Downloads the I-V characteristic in CSV format. Output values for each POINT are written in the file. You can edit the data to increase or decrease the POINT and input the output value for each POINT. To display the edited data on the Web browser interface, upload CSV files with File Upload.

## Memory

Performs startup settings, startup output state settings, and reset settings.

### Memory Config

Power ON Settings: Selects the setting state at power supply ON.

Power ON Output: Sets the output state from the DC OUTPUT terminal when turning on the power supply.

### Memory Operation

Reset Settings: Sends \*RST and returns to the reset setting ([p.55](#)).

## Preset Memory

Output value and part of protection function can be saved for later recall when necessary.

### Preset Memory Data

Displays preset memory in a list. The number of items displayed can be selected from 10 and 20 from the drop-down menu.

### Preset Memory Operation

Specifies a preset memory number and saves or recalls it.

## Setup Memory

Basic setting items can be saved for later recall when necessary.

### Setup Memory Data

The setup memory is displayed in a list. The number of items displayed can be selected from 10 and 21 from the drop-down menu.

In the 21st memory called File, the contents uploaded by File Upload will be displayed.

### Setup Memory Operation

Specifies a setup memory number and saves or recalls it.

To save or recall memory uploaded with File Upload, input File.

### Setup Memory View

Specifies the contents to be displayed in Setup Memory Data.

## File Upload

Upload the setup memory (.info file) on the Web browser interface. The uploaded data overwrites the File memory displayed in the 21st line of the Setup Memory Data.

## File Download

Download: Downloads the setup memory (.info file) of the specified number.

Save As: Saves the present settings of the PXB series as an .info file.

## Status

Display and clear alarms and SCPI errors.

### Alarm Status

Alarm Message: A message is displayed when an alarm is generated.

Detected Alarm: The alarm name is displayed when an alarm is generated.

Clear Low Alarm: Clears the Low alarm.

### SCPI Status

SCPI Error Message: A message is displayed when an SCPI error occurs.

Detected SCPI Error: An error number is displayed when an SCPI error occurs.

Clear SCPI Error: Clears SCPI errors.

## System

Input/output range settings for external control, function settings for general-purpose digital input/output, enabling/disabling of digital input/output, and buzzer sound settings.

### System EXT Range

Output Range: Sets the range of the signal to be output from the analog output terminal of the external control.

Input Range: Sets the range of the signal to be input to the analog input terminal of the external control.

### System DIGI OUT Channel

Sets the function and polarity of the general-purpose digital output terminals (Ch. 1 to Ch. 6), respectively.

### System DIGI IN Channel

Sets the function and polarity of the general-purpose digital input terminals (Ch. 1 to Ch. 6), respectively. Ch. 6 function is fixed at H ALARM IN.

### System Time

Sets date and time. Settings related to NTP servers cannot be configured.

### System Misc.

Enable DIGI I/O Channel: Enables or disables digital input/output.

Buzzer: Enables or disables buzzer sound.

## LAN Config page

You can display and change the network settings.

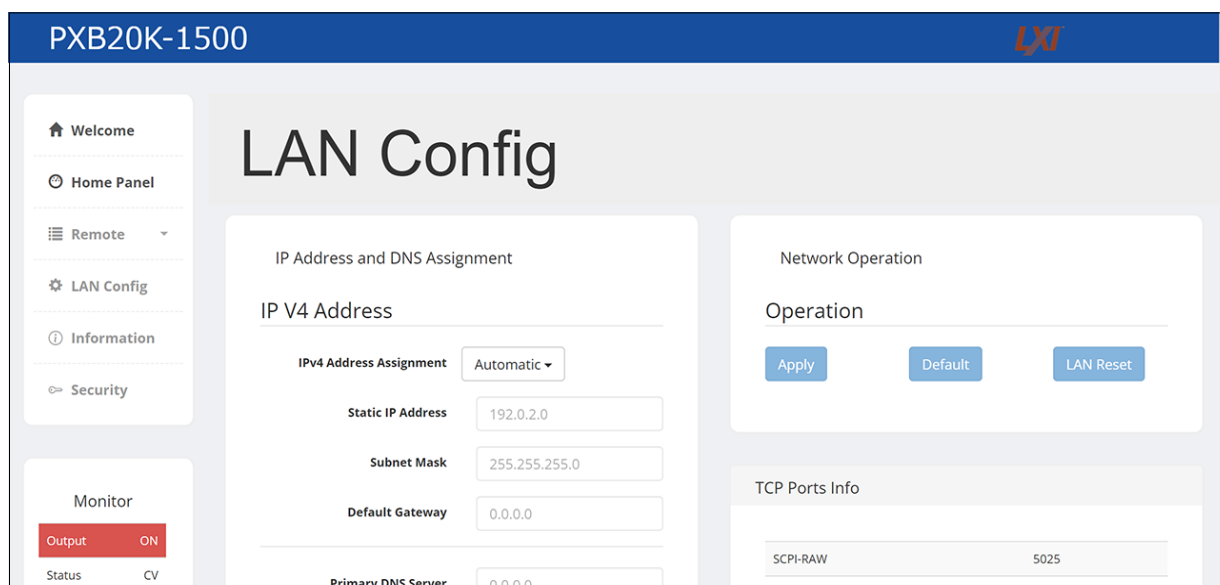

### IP Address and DNS Assignment

Configure settings related to the IP V4 address.

### Network Operation

Apply: Applies the settings configured on the LAN Config page.

Default: Returns the settings on the LAN Config page to the factory defaults.

LAN Reset: Returns the IP4 Address Assignment, Dynamic DNS, and mDNS settings on the LAN Config page and Security page (p.39) to their factory defaults.

- Factory default settings of LAN Config

Item	Factory default settings
IP4 Address Assignment	Automatic
Static IP Address	—
Subnet Mask	—
Default Gateway	—
Primary DNS Server	—
Secondary DNS Server	—
Desired Hostname	Model name and serial number
Desired Description	KIKUSUI <name> Bidirectional DC Power Supply -<serial> <name>: model name, <serial>: serial number
Dynamic DNS	Enable
mDNS	Enable

### TCP Ports

Displays the settings related to the TCP port.

### Hostname & Service

Sets the hostname and enables or disables DNS.

## Information page

This page shows the license information of the open-source software.

The screenshot shows the PXB20K-1500 Information page. The page title is "Information". On the left, there is a navigation menu with options: Welcome, Home Panel, Remote, LAN Config, Information, Security, and a Monitor section. The Monitor section shows Output ON, Status CV, Volt 9.65, Curr 5.000, Pow 48, and ALM ----. The main content area is titled "OSS Licensing Info" and contains a table of software licenses.

**OSS Licensing Info**

Information on open source software used in PXB series are provided.  
This product contains open source software under the licensing terms of GNU General Public License (GPL), GNU Lesser General Public License (LGPL), and other licenses. The source codes of the open source software used in this product are disclosed in accordance with the license conditions of GPL, LGPL, etc. For the license of each open source software, please refer to the license agreement included in the source code. Please note that we cannot answer questions regarding the contents of the source codes of open source software.

Software name	License
attr	LGPLv2.1+
base-files	GPLv2
base-passwd	GPLv2+
bootstrap	Apache-2.0
bootstrap-theme	Apache-2.0
busybox	GPLv2 & bzip2
i2c-tools	GPLv2+
init-fupdown	GPLv2
initscripts	GPLv2
jsencrypt.js	MIT License
jquery	MIT License
jquery-datatables	MIT License
jquery-ui	MIT License
kmod	LGPL-2.1+
libusb1	LGPLv2.1+
linux-ti-staging	GPLv2
mtd-utils	GPLv2+
netbase	GPLv2

### OSS Licensing Info

Displays the license information of the open-source software.

## Security page

You can set and change the password for the Web browser interface here.

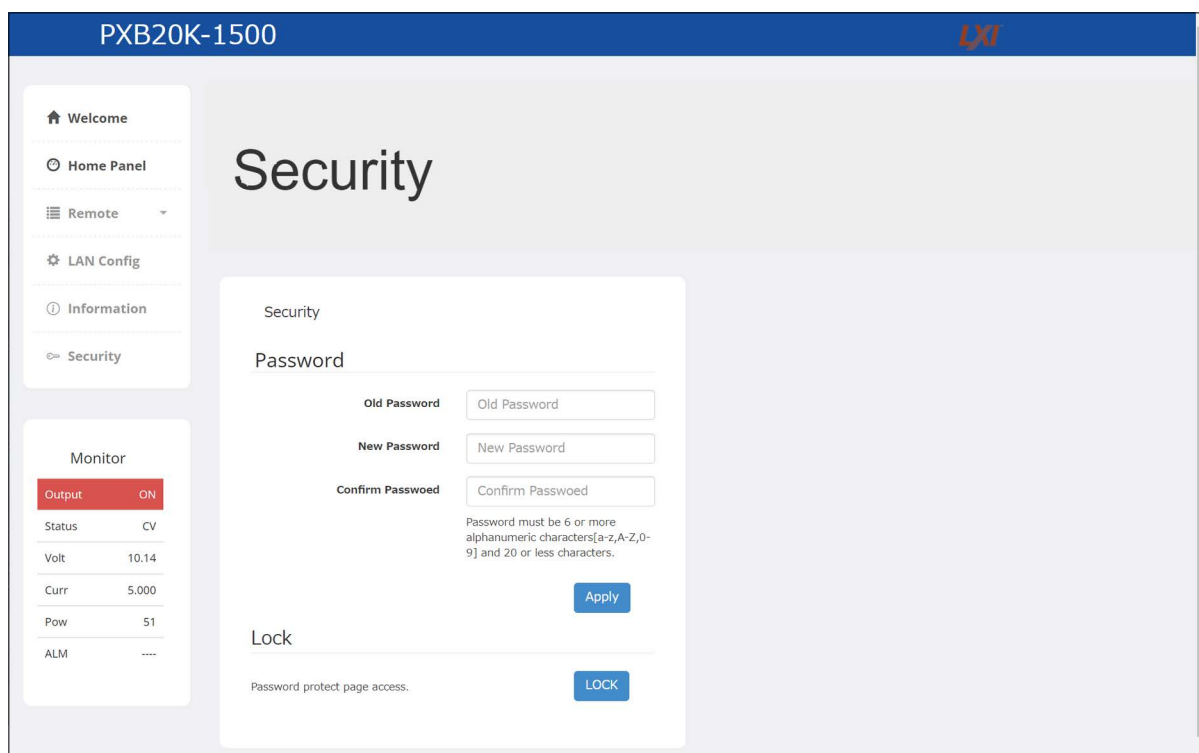

When locked with a password, the screen shown below is displayed.

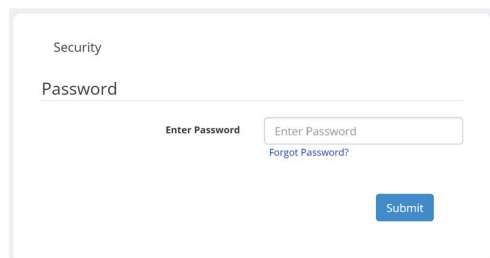

### Security

Changes the password to access the Web browser interface's Remote page, LAN Config page, and Security page. When a password is input to unlock the PXB series, the lock will remain unlocked until the PXB series is restarted. If you press LOCK, it will be immediately locked with a password.

**Password:** Sets a password. Set it with 6 or more and 20 or less alphanumeric characters. Uppercase and lowercase letters are distinguished. The factory default setting password is "kikusui." If you forget the password, return the PXB series to the factory default settings ([p.78](#)).

**Lock:** Locks with a password.

## VMCB Link page

The domain number and channel list of Multichannel (p.41) are displayed.

The screenshot shows the VMCB Link page for a PXB20K-1500 unit. The page is divided into a left sidebar and a main content area. The sidebar contains a navigation menu with the following items: Welcome, Home Panel, Remote, LAN Config, Information, Security, and VMCB Link. At the bottom of the sidebar, there is a 'Monitor' section with 'Output' and 'ON' indicators. The main content area features the title 'VMCB Link' and two primary sections: 'Domain Number' and 'Channel List'. The 'Domain Number' section displays 'Domain: 123'. The 'Channel List' section contains a table with the following data:

Channel	Model Name	Rated Volt[V]	Rated Curr[A]	Rated Pow[W]	Slave WEB Application URL
1.	PXB20K-1500	1500	30	20000	<a href="http://169.250.140.1/index.html">http://169.250.140.1/index.html</a>
2.	PXT20K-1500	1500	120	20000	<a href="http://169.250.140.2/index.html">http://169.250.140.2/index.html</a>

### Domain Number

The set domain number is displayed.

### Channel List

The channel number, model name, rated voltage, rated current, rated power, and the URL of the web browser interface of a product connected to Multichannel are displayed.

The home screens of VMCB master unit and VMCB slave unit are displayed at the lower part of the list.

# Preparation for Multichannel

PXB series with system version 3.2 and later supports virtual multichannel (VMCB).

## Multichannel

PXB series supports the virtual multichannel based on the VMCB architecture.

If you use Multichannel, you can connect one PC with up to eight units of PXB series to construct a virtual multichannel power supply system.

You can utilize this to reduce the number of communication ports, adjust the control timing among the plural units of PXB series, or the like.

Our PXB series can be mixed and connected to Multichannel. In this manual, all explanations are made referring to the cases where PXB series is used for the connection as examples.

## Connection method

Set one PXB series as a master unit (hereinafter, referred to as the VMCB master unit), and then connect this PXB series to a PC through the LAN, RS232C, or USB interface.

Set the other units of PXB series as slave units (hereinafter, referred to as VMCB slave units). Use a switching hub or a broadband router to connect the slave units to the master unit through the LAN interface.

Use standard LAN cables (category 5).

You can control PXB series units recognized as the slave units through a PXB series unit set as the VMCB master unit under Multichannel. Slave units cannot be controlled directly from a PC.

### When the VMCB master unit is connected to the PC through the LAN interface

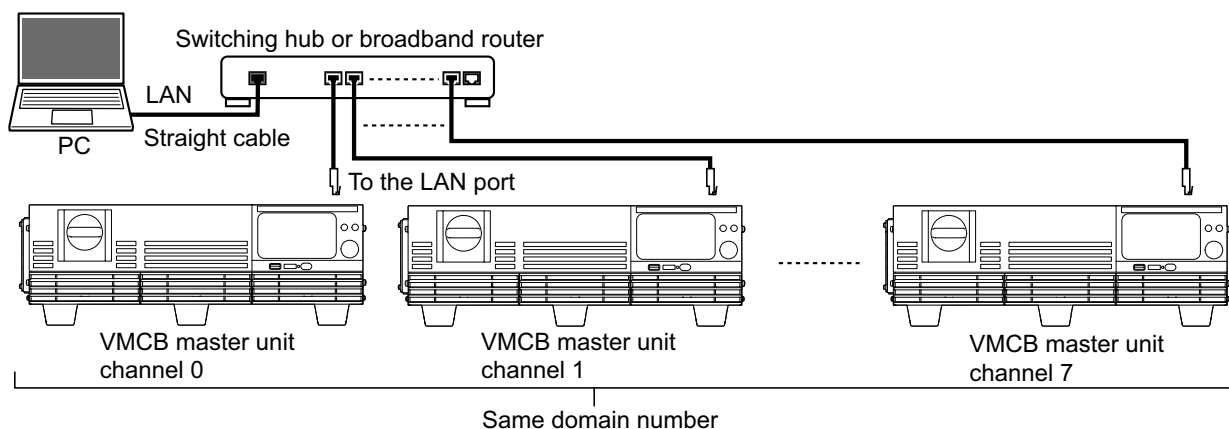

## When the VMCB master unit is connected to the PC through the RS232C or USB interface

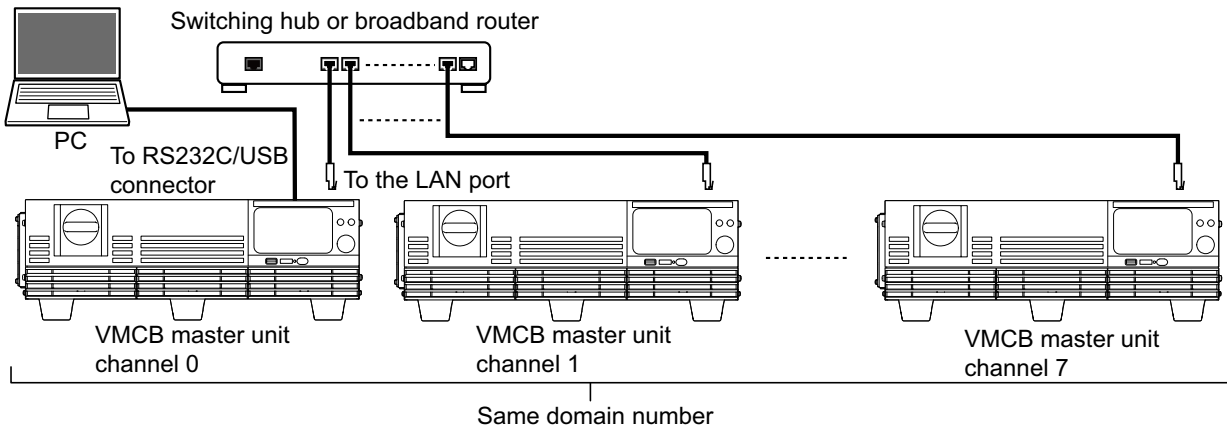

## Setting procedure

Set the multichannel function Enable/Disable, master unit, and domain number on the VMCB master unit. Set the multichannel function Enable/Disable, domain number, and channel number on the VMCB slave unit.

### Enable mDNS settings

Multichannel uses Multicast DNS (mDNS).

#### When the web browser interface is used for settings

- 1 Access LAN Config page ([p.37](#)).
- 2 Enable mDNS in Hostname & Service.  
This completes the setting.

#### When setting is made on the front panel

- 1 Press **System** > **Communication** on the homepage.  
LAN and network screens will be displayed.
- 2 Press **Edit**.
- 3 Keep pressing the **▶** key to switch pages until the check box of mDNS is displayed.
- 4 Press the check box of mDNS to mark a check.  
This completes the setting.

## Set Multichannel

### 1 Press System > VMCB > Edit on the homepage.

Multichannel setup screen is displayed.

### 2 Set Enable/Disable of VMCB.

Press the check box of VMCB Enable.

Each time you press the check box, the existence of checking changes. With a check mark, it is enabled, without a check, it is disabled.

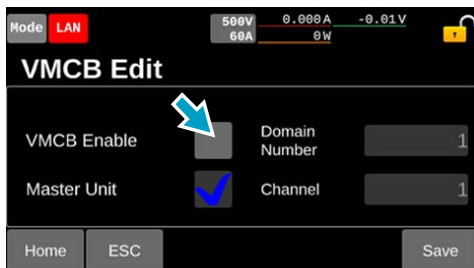

### 3 Set VMCB master and slave units.

Press the check box of Master Unit.

Each time you press the check box, the existence of checking changes. With the check, it is set as the VMCB master unit, without the check, it is set as a VMCB slave unit.

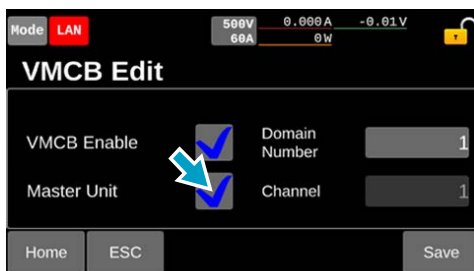

### 4 Set the Domain number.

Press the input field for Domain Number and input the domain number on the display or with the rotary knob.

Setting range: 1 to 254

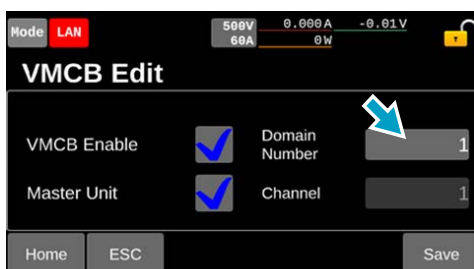

## 5 When it is set as a VMCB slave unit in Step 3, set a channel number.

Press the input field for Channel and input the channel number on the display or with the rotary knob. Setting of channel number is not necessary for the VMCB master unit.

Setting range: 1 to 7

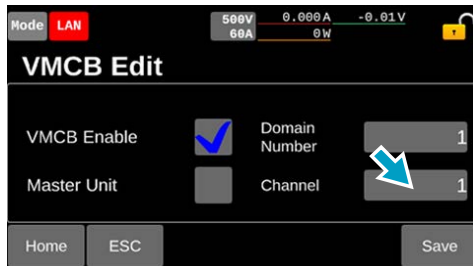

## 6 Press Save.

A confirmation screen appears.

## 7 Press OK.

Multichannel setup confirmation screen is displayed.

## 8 Turn the POWER switch off.

## 9 Set all the units connected to Multichannel following Step 1 to Step 8.

## 10 Turn the POWER switches ON in the order of VMCB slave unit to VMCB master unit, or turn the POWER switches of all units ON simultaneously.

This completes the setting.

## Check the configuration of Multichannel

You can query the channel list in INST:CAT? (p.68).

# About Commands

The information that is transferred between the controller (PC) and this product is referred to as messages. This product uses the SCPI language for these messages.

The messages that the PC sends to this product are commands. The messages that this product sends to the PC are responses.

## Command Hierarchy

SCPI is an ASCII-based command language that was designed for test and measuring equipment. The command structure is composed of the common roots or nodes that are the building blocks of the SCPI subsystem. A command consists of a program header, parameters, and punctuation marks.

The following table uses the SOURce subsystem as an example to explain the hierarchy.

Program header	Parameter	Node level
[:SOUR]		Root node
:CURR	<numeric>	Level 2
:POW		Level 2
:PROT		Level 3
:UPP	<numeric>	Level 4
:LOW	<numeric>	Level 4

A colon (:) separates a higher node from a lower node.

# Command Syntax

## NOTE

To use the communication interface, you must enable the remote control by issuing the command: SYST:COMM:RLST REM. To use remote programming, send "SYST:COMM:RLST REM" at the beginning of the program.

In this manual, SCPI commands are expressed in the following format.

```
[[:SOURCE]:CURRENT[:LEVEL][:IMMEDIATE][:AMPLITUDE] <numeric>
```

SCPI commands are also available in the short form. In the short form, the lowercase characters in SCPI commands are omitted.

SCPI commands can be sent either in the long form or short form. Because SCPI commands are not case-sensitive, VOLT, Volt, and volt are all acceptable as short form notations. In the long form, VOLTAGE, Voltage, and voltage are all acceptable.

- A space separates a program header and its parameters.
- Multiple parameters are separated by commas.
- Multiple commands are separated by semicolons (compound command).

```
:SOURCE:CURRENT:PROTECTION:UPPER 15;LOWER 1
```

In the second command, SOURCE:CURRENT:PROTECTION: is omitted. This is because the first command, SOURCE:CURRENT:PROTECTION:UPPER, specifies the path to SOURCE:CURRENT:PROTECTION.

This compound command is equivalent to entering the following commands.

```
:SOURCE:CURRENT:PROTECTION:UPPER 15
:SOURCE:CURRENT:PROTECTION:LOWER 1
```

If you specify a node that is not defined in the current path, an error will occur.

By using colons and semicolons, you can concatenate commands of different subsystems.

```
:SOURCE:CURRENT 3;:TRIGGER:ACQUIRE
```

There are two root nodes in this compound command: SOURCE and TRIGGER.

When the second command or later begins with a colon, the path that was specified by the previous command is cleared. The maximum length of a command that you can transmit on a single line is 512 bytes.

## Special symbols

The special symbols that are used in this manual for the SCPI command syntax are explained below.

- Characters and numbers enclosed by { and } and delimited by "|" indicate that one of the delimited items is to be selected.  
Do not include the { and } symbols in the actual program.
- <> denotes program data.  
Do not include the < and > symbols in the actual program.
- [ ] denotes optional data.  
When optional data is not sent with the program, the default value is applied. Do not include the [ and ] symbols in the actual program.

## Query

---

You can query the device settings and status.

To make a query, append a question mark to the end of the program header section. If the query has parameters, insert a space after the question mark, and then write the parameters.

```
:CURR? MIN
```

## Response

This is the response to a query. It is a message always sent from the device to the PC. It conveys device status or measured value to the PC.

---

### NOTE

If you want to send two queries on separate lines, send the second query after you have received the response to the first one.

---

## Program terminator

---

All commands must be terminated with a valid terminator.

The terminator for receiving and sending is LF (line feed, ASCII 0x0A) or EOI (end of identify, only for USB). When you terminate a command string, the path is reset to the root level.

---

### NOTE

CR (ASCII 0x0D) is not a terminator.

---

## Common commands

---

There are commands that are common to the IEEE-488.2 and SCPI standards for functions such as resetting devices and performing self-diagnoses. These common commands start with an asterisk ("\*"). These commands may have one or multiple parameters.

## Parameter

---

The SCPI parameter format is derived from the program parameter format that is defined in IEEE 488.2. The program data expression format that the this product uses is shown below.

### Non-numeric parameters

#### String data (String)

String data is used when a series of ASCII characters (20H to 7EH) are requested.

Enclose strings in single (") or double quotation (") marks. The opening and closing quotation marks must match (you cannot mix single and double quotation marks).

```
0, "No error"
```

If you want to include a quotation mark as part of the string, enter consecutive quotation marks (with no characters between them).

#### Character data (Character)

Character data is used when only a limited number of values are available for a program setting. Responses are returned in short form.

```
:TRIGger:ACQuire:SOURce {IMMediate|BUS}
```

#### Boolean data (Boolean)

Boolean data is used to express a condition of 1 or 0, or ON or OFF. Responses are returned as 1 or 0.

```
:SYSTem:KLOCK {ON|OFF|1|0}
```

### Numeric parameters

NR1, NR2, and NR3 are described in detail in the IEEE Std 488.2 standard stated in the first part of Measuring instrument interface standards ([p. 17](#)).

#### NR1

Represents an integer value.

If 0 is returned in the response data, it is returned as +0.

#### NR2

Represents a real number in floating-point format.

Details are given in the "IEEE 488.2 Standard Digital Interface for Programmable Instrumentation."

#### NR3

Represents a real number in scientific notation.

If 380 is returned in the response data, it is returned as +3.80000E+02. Five decimal places are used.

#### NRf

NRf is a generic term that includes NR1, NR2, and NR3.

If a value outside the setting range is specified, an error (-222, "Data out of range") will occur.

## Numeric

Numeric parameter for values such as the decimal point, optional prefixes, and measurement units.

Numbers are expressed the same as NRf. MINimum, MAXimum, and the like are available as substitutes for declaring certain values.

You can also use units such as V, A, and W in numeric parameters.

If a value outside the setting range is specified, an error (-222, "Data out of range") will occur.

## Substitutes (Minimum value, Maximum value)

---

The special form numeric parameters MINimum and MAXimum can be used as substitutes for the actual maximum and minimum values when the parameter is numeric.

The following example sets the output current to the minimum value.

```
:CURRent MINimum
```

You can query the minimum and maximum values for most parameters.

```
:CURR? MAX
```

```
:CURR? MIN
```

## Measurement units

---

The default measurement units are listed below. Commands are accepted even if measurement units are not specified.

V (voltage)	A (current)	HZ (frequency)	OHM (resistance)
S (seconds)	MIN (minutes)	HR (hours)	

The following optional prefixes are supported. If you use optional prefixes, specify the measurement unit.

G (giga)	M (milli, mega)	K (kilo)
P (pico)	U (micro)	

### NOTE

- The unit symbols in the International System of Units contain lowercase characters. The IEEE standard uses uppercase characters. SCPI commands are not case sensitive.
- Commands are accepted whether or not measurement units are specified.
- The optional prefix "M" is interpreted as "mega" when the measurement unit is "HZ" or "OHM." For other measurement units, it is interpreted as "milli."
- To enter "μ" in the data, use "U" instead.

# IEEE 488.2 Common Commands

Applicable commonly to the units conforming to IEEE488.2.

## \*CLS

Clears all event registers including the status byte, event status, and error queue.  
Clears the operations waiting for being completed by \*OPC or \*OPC?.

### Command

\*CLS

## \*ESE

Sets the event status enable register that is counted by the event summary bit (ESB) of the status byte.

### Command

\*ESE <NRf>  
\*ESE?

### Parameter

Set value: 0 to 255

Example: When \*ESE 16 is transmitted, bit 4 of the event status enable register is set. Each time the execution error bit (bit 4) of the event status register is set, the summary bit (ESB) of the status byte is set.

### Response

NR1

## \*ESR?

Queries the event status register.  
The event status register is cleared when read.

### Command

\*ESR?

### Response

NR1

## \*IDN?

Queries the model name and firmware version of this product.

### Command

\*IDN?

### Response

Example response: When the model name is PXB20K-500, the serial number is AB123400, and the system version is 01.00.0000

KIKUSUI, PXB20K-500, AB123400, VER01.00.0000

## \*OPC

Sets the OPC bit (bit 0) of the event status register when all the commands that are in standby have been processed. See IEEE 488.2-1992 section 12.5.3.

### Command

\*OPC

\*OPC?

### Response

Returns "1" when the processing of all queued commands has been complete.

## \*OPT?

Queries the installed options.

### Command

\*OPT?

### Response

"VMCB" (Virtual multichannel function) returns.

## \*PSC

Sets whether the event status enable register and service request enable register are cleared when the POWER switch is turned on.

### Command

```
*PSC <boolean>
*PSC?
```

### Parameter

Set value:	ON (1)	When the POWER switch is turned on, the *ESE and *SRE settings are cleared. (default)
	OFF (0)	When the POWER switch is turned on, the *ESE and *SRE settings are not cleared.

### Response

boolean

### Example

```
*PSC 0;*SRE 32;*ESE 128
```

## \*RCL

Recalls setup memories.

Cancels the trigger subsystem operation. You cannot run the operation during output. For the commands affected, see “List of Parameters Applicable to \*RCL, \*RST, and \*SAV and Each Setting Command” ([p.55](#)).

### Command

```
*RCL <NRf>
```

### Parameter

Set value: 1 to 20 Memory number

### Example

```
*RCL 1
```

## \*RST

Resets the panel settings.

Clears the OPC bit (bit 0) of the event status register. The alarm is not cleared.

You cannot run the operation during output. For the commands affected, see “List of Parameters Applicable to \*RCL, \*RST, and \*SAV and Each Setting Command” ([p.55](#)).

### Command

```
*RST
```

## \*SAV

Saves the panel settings to the setup memory.

For the commands affected, see “List of Parameters Applicable to \*RCL, \*RST, and \*SAV and Each Setting Command” (p.55).

### Command

```
*SAV <NRf>
```

### Parameter

Set value: 1 to 20 Memory number

### Example

```
*SAV 1
```

## \*SRE

Sets the service request enable register.

The service request enable register can be used to select which summary messages in the status byte register will perform service requests.

To clear the service request enable register, send \*SRE 0. If the register is cleared, service requests cannot be generated using status information.

### Command

```
*SRE <NRf>
```

```
*SRE?
```

### Parameter

Set value: 0 to 255

Example: Sending \*SRE 8 sets bit 3 of the service request enable register. Each time the summary bit (bit 3) of the QUESTIONable status register in the status byte is set, a service request message is generated.

### Response

```
NR1
```

## \*STB?

Queries the contents of the status byte register and the MSS (master summary status) message.

The response is the same as serial polling only with the exception that the MSS message appears in place of the RQS message in bit 6.

### Command

```
*STB?
```

### Response

```
NR1
```

## \*TRG

Trigger command.

Executes a trigger on the trigger group. This is a substitute command for IEEE 488.1 get (Group Execute Trigger). If the device is in a state in which it does not accept triggers, an SCPI error (-211, "Trigger ignored") occurs. See IEEE 488.2-1992 section 10.37.

### Command

\*TRG

## \*TST?

Executes a self-test.

You can check which error occurred with SYST:ERR? command. See IEEE 488.2-1992 section 10.38.

### Command

\*TST?

### Response

If there is no problem, returns 0 in response to \*TST?. Returns an error code if there is a problem.

## \*WAI

Prevents the PXB series from executing subsequent commands until all operations that are in standby have completed.

### Command

\*WAI

## List of Parameters Applicable to \*RCL, \*RST, and \*SAV and Each Setting Command

Command	Factory default settings
DATA:INT:GATE	OSON
DATA:INT:GATE:RES	AUTO
FUNC:MODE	CV
FUNC:OFF:MODE	LOW
CURR	MINimum
CURR:NEG	MINimum
CURR:FUNC:MODE	DC
CURR:IV:COUN	3
CURR:PROT	MAXimum
CURR:NEG:PROT	MAXimum
CURR:PROT:DEL	MINimum
CURR:PULS:DCYC	MINimum
CURR:PULS:FREQ	MINimum
CURR:PULS:HIGH	0 A
CURR:PULS:LOW	0 A
CURR:RESP	FAST
CURR:SEAM	0 A
CURR:SINE:AMPL	MINimum
CURR:SINE:FREQ	MINimum
CURR:SINE:OFFS	0 A
CURR:SLEW	Rated output current / 4
OUTP	0
POW	MAXimum
POW:NEG	MAXimum
POW:FUNC:MODE	DC
POW:PROT	MAXimum
POW:NEG:PROT	MAXimum
POW:SEAM	MAXimum
RES:IR	MINimum
VOLT	MINimum
VOLT:FUNC:MODE	DC
VOLT:IV:COUN	3
VOLT:PROT	MAXimum
VOLT:PROT:LOW	MINimum
VOLT:PROT:LOW:STAT	OFF
VOLT:PULS:DCYC	MINimum
VOLT:PULS:FREQ	MINimum
VOLT:PULS:HIGH	0 V
VOLT:PULS:LOW	0 V
VOLT:RESP	FAST
VOLT:SINE:AMPL	MINimum

Command	Factory default settings
VOLT:SINE:FREQ	MINimum
VOLT:SINE:OFFS	MINimum
VOLT:SLEW	Rated output voltage / 4
SENS:APER	0.1 S
SYST:PROT:LINE:VOLT	MAXimum
TRIG:ACQ:COUN	MINimum
TRIG:ACQ:DEL	MINimum
TRIG:ACQ:INT:STAT	0
TRIG:ACQ:INT:TIME	0.1 S
TRIG:ACQ:SOUR	IMMediate

# ABORt Command

Aborts the ongoing measurement operations and sequence operations.

## ABOR

Aborts measurement operations and sequence operations.

The product's trigger state immediately after it turns on is the same as its trigger state after it receives an ABOR command. If an ABOR command is sent when the trigger function is not running, the measurement data is not discarded.

### Command

```
:ABORt [:ALL]
```

## ABOR:ACQ

Aborts measurement operations.

If an ABOR command is sent when the trigger function is not running, the measurement data is not discarded.

### Command

```
:ABORt:ACQuire
```

## ABOR:TRAN

Cancels the sequence operation.

### Command

```
:ABORt:TRANsient
```

# ANALog Command

Relates to the analog I/O of the EXT CONT connector.

## ANAL:CONT:SEL:RANG

Sets the voltage range of the signal input to the EXT CONT connector when externally controlling the output from the DC OUTPUT terminal in the CC or CP mode.

To enable the external control of the CC mode, set CURR:FUNC:MODE (p.109) to EXT.

To enable the external control of the CP mode, set POW:FUNC:MODE (p.122) to EXT.

### Command

```
:ANALog:CONTRol:SElectied:RANGe[:UPPer] <NRf>  
:ANALog:CONTRol:SElectied:RANGe[:UPPer]?
```

### Parameter

Set value:	5	Sets the voltage to the range from 0 V to 5 V.
	10	Sets the voltage to the range from 0 V to 10 V. (default)

When you enter a value that is less than 10, the voltage is set to the range from 0 V to 5 V.

Unit: V

### Response

NR3

### Example

```
ANAL:CONT:SEL:RANG 10.0
```

## ANAL:CONT:VOLT:RANG

Sets the voltage range of the signals to the EXT CONT connector when this product is controlled externally in the CV mode.

To enable the external control of the output, VOLT:FUNC:MODE (p.126) to EXT.

### Command

```
:ANALog:CONTRol:VOLTagE:RANGe[:UPPer] <NRf>
:ANALog:CONTRol:VOLTagE:RANGe[:UPPer]?
```

### Parameter

Set value:	5	Sets the voltage to the range from 0 V to 5 V.
	10	Sets the voltage to the range from 0 V to 10 V. (default)

When you enter a value that is less than 10, the voltage is set to the range from 0 V to 5 V.

Unit: V

### Response

NR3

### Example

```
ANAL:CONT:VOLT:RANG 5.0
```

## ANAL:MON:CURR:RANG

Sets the voltage range of the signal from the EXT CONT connector when this product is controlled externally in the CC mode.

To enable the external control of the output, set CURR:FUNC:MODE (p.109) to EXT.

### Command

```
:ANALog:MONitor:CURRent:RANGe[:UPPer] <NRf>
:ANALog:MONitor:CURRent:RANGe[:UPPer]?
```

### Parameter

Set value:	5	Sets the voltage to the range from 0 V to 5 V.
	10	Sets the voltage to the range from 0 V to 10 V. (default)

When you enter a value that is less than 10, the voltage is set to the range from 0 V to 5 V.

Unit: V

### Response

NR3

### Example

```
ANAL:MON:CURR:RANG 5.0
```

## ANAL:MON:VOLT:RANG

Sets the voltage range of the signal from the EXT CONT connector when this product is controlled externally in the CV mode.

To enable the external control of the output, VOLT:FUNC:MODE ([p. 126](#)) to EXT.

### Command

```
:ANALog:MONitor:VOLTage:RANGe[:UPPer] <NRf>
:ANALog:MONitor:VOLTage:RANGe[:UPPer]?
```

### Parameter

Set value:	5	Sets the voltage to the range from 0 V to 5 V.
	10	Sets the voltage to the range from 0 V to 10 V. (default)

When you enter a value that is less than 10, the voltage is set to the range from 0 V to 5 V.

Unit: V

### Response

NR3

### Example

```
ANAL:MON:VOLT:RANG 10.0
```

# DATA Command

Relates to measurement values and integration.

## DATA:INT:GATE

Sets the period of recording the integrated values.

### Command

```
:DATA:INTEgral:GATE <character>  
:DATA:INTEgral:GATE?
```

### Parameter

Set value:	MANual	Starts/stops the integrated value recording manually using the display.
	OSON	Recording is started/stopped automatically in synchronization with output ON/OFF. (default)
	EXTernal	Integration starts/stops when a signal is input for the general-purpose digital input of the EXT CONT connector. Enabled for channels in which IO:INP:FUNC is set as INT.
	PRUN	Integration is started/stopped interlocking with sequence execution.

Settings are reset to default when the \*RST command is sent.

### Response

character

### Example

```
DATA:INT:GATE OSON
```

## DATA:INT:GATE:RES

Sets the condition to reset the recorded integrated value.

### Command

```
:DATA:INTEgral:GATE:RESet <boolean>
:DATA:INTEgral:GATE:RESet?
```

### Parameter

Set value:	MANual	The value is reset by pressing Resetjdt on the PXB series unit display.
	AUTO	The value is automatically reset before starting the integration. (default)
	EXTernal	The value is reset when a signal is input to the EXT CONT connector.

Settings are reset to default when the \*RST command is sent.

### Response

boolean

### Example

```
DATA:INT:GATE:RES AUTO
```

## DATA:INT:RES

Resets all integrated values (for integrated current, integrated power, and elapsed time).

### Command

```
:DATA:INTEgral:RESet
```

## DATA:INT:STAR

Starts integrated value recording.

### Command

```
:DATA:INTEgral:STARt
```

## DATA:INT:STOP

Stops integrated value recording.

### Command

```
:DATA:INTEgral:STOP
```

## DATA:REM?

Queries the measured values registered in the data logger from oldest to youngest.

### Command

```
:DATA:REMAins[:NEXT]? [<NRf>]
```

### Parameter

Value: Specifies the number of data for reference in the NRf format from 1 to 50. Queries 50 data when omitting.

### Response

Returns in the order of voltage (V), current (A), power (W), elapsed time (sec), current capacity (Ah), and power capacity (Wh), comma-separated, in NR3 for each measured value recorded in the data logger.

### Example

```
DATA:REM? 10
```

## DATA:REM:POIN?

Queries the number of the remaining measured values that can be queried with DATA:REM?

### Command

```
:DATA:REMAins:POINts?
```

### Response

NRf

# DIAGnostic Command

Relates to product maintenance.

## DIAG:FIRM:VERS?

Queries the detailed version information on this product.

### Command

```
:DIAGnostic:FIRMware:VERSion?
```

### Response

character

Returns the detailed version information with comma-separated values.

## DIAG:LINE:POW?

Queries the power of the AC power line.

### Command

```
:DIAGnostic:LINE:POWer?
```

### Response

NR3

Unit: W

# DISPlay Command

Relates to display settings.

## DISP:BRIG

Sets the intensity of the display.

### Command

```
:DISPlay:BRIGhtness <NRf>  
:DISPlay:BRIGhtness?
```

### Parameter

Set value: 1 to 7 (Default: 7)

Settings are reset to default when the \*RST command is sent.

### Response

NR1

### Example

```
DISP:BRIG 4
```

# GLOBAL command

Corresponds to all channels that have the same domain under Multichannel.  
For Multichannel, refer to "Preparation for Multichannel" (p.41).

## GLOB:OUTP

For all channels that are configured under the same domain under Multichannel, sets the output ON/OFF by sending OUTP.

If you set it to OUTPUT OFF while a sequence is running, a sequence will be forcefully stopped and the output will be turned off.

### Command

```
:GLOBal:OUTPut[:STATe]  
:GLOBal:OUTPut[:STATe]?
```

### Parameter

Set value:	ON(1)	OUTPUT ON
	OFF(0)	OUTPUT OFF (default)

When set to OFF, an interval of 80 ms or more is required until it is turned ON next.

Settings are reset to default when the \*RST command is sent.

### Response

boolean

### Example

```
GLOB:OUTP ON
```

# INITiate Command

Starts trigger function.

## INIT:ACQ

Initiates measurement.

TRIG:ACQ:SOUR (p.141) is set to IMM, measurement is immediately started. If it is set to other than IMM, the system switches to the trigger wait state, and measurement is started with the respective conditions. Executing this command deletes all the measurement records in the data logger.

When TRIG:ACQ:INT:STAT (p.139) is ON, measurement does not start if the SENS:APER (p.106) time is longer than the TRIG:ACQ:INT:TIME (p.140) time.

### Command

```
:INITiate[:IMMediate]:ACquire
```

## INIT:TRAN:PROG

Starts the sequence start trigger function in the program registered in the chain.

If TRIG:TRAN:SOUR (p.143) is set to IMM, the sequence is immediately started. If it is set to other than IMM, the system switches to the trigger wait state, and the sequence is started with the respective conditions.

Sequence cannot be executed if no program is registered in the chain. Register the program in the chain in PROG:CHA:ADD (p.87).

If the number of steps of the program is large, sending INIT:TRAN:PROG right after registering the chain with PROG:CHA:ADD will take time before the trigger function starts (approximately 1 second for 1000 steps as a rough estimation).

---

## NOTE

Chain is unlocked in the following cases: Register the program in the chain again in PROG:CHA:ADD.

- When turning off the power supply of the PXB series
  - When creating a new program
  - When changing settings of/deleting a program registered in the chain or a program not registered in the chain
- 

### Command

```
:INITiate[:IMMediate]:TRANsient:PROGram
```

# INSTrument Command

Relates to the channels controlled under Multichannel.  
For Multichannel, refer to "Preparation for Multichannel" (p.41).

## INST

Specifies a channel to be controlled.  
You can query the channels to be specified in INST:CAT? (p.68).

### Command

```
:INSTrument[:SElect] <NR1>  
:INSTrument[:NSElect]?
```

### Parameter

Set value:	0	VMCB master unit (default)
	1 to 7	The channels of VMCB slave units

### Response

Specified channels return by NR1.

### Example

```
INST 3
```

## INST:CAT?

Queries the list of channels that can be specified in INST.

### Command

```
:INSTrument:CATalog?
```

### Response

Returns the settable channels in the NR1 [,NR1,NR1,...] format. If it is not used as Multichannel, this query returns "+0."

Set value:	+0	VMCB master unit
	+1 to +7	The channels of VMCB slave units

### Response example

When the VMCB slave units of channel 1 and channel 7 are available other than the VMCB master unit:  
+0,+1,+7

## INST:INFO?

Queries the rated voltage, rated current, rated power, and model name of the channel specified in INST.

### Command

```
:INSTrument:INFO?
```

### Response

```
<nr3>,<nr3>,<nr3>,<character>
```

Returns the maximum voltage, maximum current, maximum power, and model name in a comma-separated format.

### Response example

When the model of the specified channel is PXB20K-1500 (maximum voltage of 1500 V, maximum current of 30 A, and maximum power of 20000 W):

```
+1.50000E+03,+3.00000E+01,+2.00000E+04,PXB20K-1500
```

# IO Command

Allows you to configure the settings for the digital I/O of the EXT CONT connector.

## IO:INP:FILT

Sets the input time filter for the digital input of the EXT CONT connector.

You can use six channels for the digital input and set a filter for the respective channels.

Cannot be set when IO:STAT (p.74) is ON.

### Command

```
:IO:INPut:FILTer <character>,<character>,<character>,<character>,<character>,<character>
:IO:INPut:FILTer?
```

### Parameter

Set parameters to each channel in the order of Ch.1, Ch.2, Ch.3, Ch.4, Ch.5, and Ch.6.

Set value:	FAST	Activated when the digital input terminal receives an input for 150 $\mu$ s. This is recommended when using semiconductor switches, etc. (default)
	SLOW	Activated when the digital input terminal receives an input for 10 ms. This is recommended if you are using relays, etc. that may cause chattering.

### Response

character

### Example

For setting Ch.1 to Ch.3 to FAST and Ch.4 to Ch.6 to SLOW

```
IO:INP:FILT FAST,FAST,FAST,SLOW,SLOW,SLOW
```

## IO:INP:FUNC

Sets the operation to be implemented when a signal is input for the general-purpose digital input of the EXT CONT connector.

You can use five channels for the general-purpose digital input and specify the desired operation for the respective channels. Cannot be set when IO:STAT (p.74) is ON.

### Command

```
:IO:INPut:FUNctIon <character>,<character>,<character>,<character>,<character>
:IO:INPut:FUNctIon?
```

### Parameter <character>

Set parameters to each channel in the order of Ch.1, Ch.2, Ch.3, Ch.4, and Ch.5.

Set value:	NONE	OFF (default)
	ON	When the signal is set to ON from OFF, the output from the DC OUTPUT terminal will become the ON state.
	OFF	While the signal setting is ON, the output from the DC OUTPUT terminal will become the OFF state.
	CONTRol	When the signal is set to ON from OFF, the output from the DC OUTPUT terminal will become the ON state. While the signal setting is OFF, the output from the DC OUTPUT terminal will become the OFF state.
	LALM	While the signal setting is ON, a LOW alarm will be generated, and the output from the DC OUTPUT terminal becomes the OFF state.
	CLR	When the signal is set to ON from OFF, the LOW alarm is cleared. If L ALARM IN is being set ON simultaneously, L ALARM IN will be prioritized.
	TINitiate	When the signal is set to ON from OFF, the sequence will be started. When the signal is set to OFF from ON, the sequence will be cancelled.
	TPAUse	When the signal is set to ON from OFF, the sequence will be paused. When the signal is set to OFF from ON, the sequence will be resumed.
	INTegral	While the signal setting is ON, the elapsed time, current, and power are integrated. When the signal is set to OFF, integration stops.
	IRESet	While the signal setting is ON, the integrated values of elapsed time, current, and power are reset.
	ACQuire	When the signal is set to ON from OFF, the measurement trigger will be input. TRIG:ACQ:SOUR (p.141) is in the trigger wait state at EXT, the measurement will start.
	TRANsient	When the signal is set to ON from OFF, the sequence trigger will be input. When the TRIG:TRAN:SOUR (p.143) is in the trigger wait state with EXT, the sequence will be started.
	MEM1	If the signal is set to ON, preset memory 2 will be recalled. <sup>1</sup>
	MEM2	If the signal is set to ON, preset memory 2 will be recalled. <sup>1</sup> If it is set to ON simultaneously with MEM1, MEM1 will be prioritized.

1. While the signal setting is ON, the set values to be saved in the preset memory cannot be changed.

### Response

character

### Example

For setting Ch.1 to OFF, Ch.2 to ON, Ch.3 to CLR, Ch.4 to INTegral, and Ch.5 to ACQ

```
IO:INP:FUNC OFF,ON,CLR,INT,ACQ
```

## IO:INP:POL

Sets the polarity for the input signal from the digital input of the EXT CONT connector. You can use six channels for the digital input and set the polarity to the respective channels. Cannot be set when IO:STAT (p.74) is ON.

### Command

```
:IO:INPut:POLarity <character>,<character>,<character>,<character>,<character>,<character>
:IO:INPut:POLarity?
```

### Parameter

Set parameters to each channel in the order of Ch.1, Ch.2, Ch.3, Ch.4, Ch.5, and Ch.6.

Set value:	NORMal	It turns on when a current of 1.5 mA or more flows into the channel. (default)
	INVerted	It turns on when the current at the channel drops to 0.1 mA or lower.

### Response

character

### Example

For setting all channel filters to NORM

```
IO:INP:POL NORM,NORM,NORM,NORM,NORM,NORM
```

## IO:OUTP:FUNC

Sets the operation to be implemented when a signal is output for the general-purpose digital output of the EXT CONT connector.

You can use six channels for the general-purpose digital output and specify the desired operation for the respective channels. Cannot be set when IO:STAT (p.74) is ON.

### Command

```
:IO:OUTPut:FUNction <character>,<character>,<character>,<character>,<character>,<character>
:IO:OUTPut:FUNction?
```

### Parameter <character>

Set parameters to each channel in the order of Ch.1, Ch.2, Ch.3, Ch.4, Ch.5, and Ch.6.

Set value:	NONE	OFF (default)
	ON	The signal is turned on while outputting from the DC OUTPUT terminal.
	PON	The signal is turned on while outputting from the DC OUTPUT terminal is ready.
	HALM	The signal is turned on after a HIGH alarm is generated until it is cleared.
	LALM	The signal is turned on after a LOW alarm is generated until it is cleared.
	CV	The signal is turned on while operating in the CV mode.
	CC	The signal is turned on while operating in the CC mode.
	PTOut	Outputs a signal with the setting of PROG:STEP<n>:TRIG:GEN (p.104).
	PRUN	The signal turns on while a sequence is running.
	DIN	The signal is turned on while the digital input of the EXT CONT connector is busy. When using both external control and remote control, monitor the EXT DIN BUSY signal. During the busy state, control not to input any signal to the digital input terminal.
	MEM1	When Preset Memory 1 is recalled by a general-purpose digital output, the signal is turned on until the set value is changed after the memory is recalled.
	MEM2	When Preset Memory 2 is recalled by a general-purpose digital output, the signal is turned on until the set value is changed after the memory is recalled.
	RELay	The signal setting is set to on/off in step with on/off of the DC OUTPUT terminal output. The signal is output after approx. 100 ms from the output on/off. You can set this parameter to only Ch.6.

### Response

character

### Example

For setting Ch.1 to MEM1, Ch.2 to ON, Ch.3 to PON, Ch.4 to CC, Ch.5 to CV, and Ch.6 to HALM

```
IO:OUTP:FUNC MEM1,ON,PON,CC,CV,HALM
```

## NOTE

When you set DIN to any of the channels with IO:STAT set to ON, be careful of the following:

- The command processing speed becomes slower than when DIN is not set. (p.188)
- Sending control commands at intervals shorter than 5 ms may stop the operation of PXB series.

## IO:OUTP:POL

Sets the polarity of the output signal from the digital output of the EXT CONT connector. You can use six channels for the digital output and set the polarity to the respective channels. Cannot be set when IO:STAT (p.74) is ON.

### Command

```
:IO:OUTPut:POLarity <character>,<character>,<character>,<character>,<character>,<character>
:IO:OUTPut:POLarity?
```

### Parameter

Set parameters to each channel in the order of Ch.1, Ch.2, Ch.3, Ch.4, Ch.5, and Ch.6.

Set value:	NORMal	It turns on when a current of 1.5 mA or more flows through the channel. (default)
	INVerted	It turns on when the current at the channel drops to 0.1 mA or lower.

### Response

character

### Example

For setting all channel filters to NORM

```
IO:OUTP:POL NORM,NORM,NORM,NORM,NORM,NORM
```

---

## NOTE

If the channel's general-purpose digital output function is set to PON and the polarity is set to INVerted, you cannot monitor whether outputting from the DC OUTPUT terminal is ready or not. This is because the channel is open before and after the power is turned on as well as when outputting is ready. In this case, the channel with PON will be closed once when the power is turned off, and will be open again when the power is completely turned off.

---

## IO:STAT

Enables/disables the digital I/O of the EXT CONT connector. Settings cannot be configured while a sequence is running.

### Command

```
:IO:STATe <boolean>
:IO:STATe?
```

### Parameter

Set value:	ON (1)	Enabled
	OFF (0)	Disabled (default)

### Response

boolean

### Example

```
IO:STAT ON
```

# MEASure / READ / FETCh Command

Queries the measurement results.

Each command is different in the following ways.

- MEAS restores the SENSE subsystem (p.106) and TRIG:ACQ:COUN (p.138), TRIG:ACQ:DEL (p.139), TRIG:ACQ:INT:STAT (p.139), TRIG:ACQ:INT:TIME (p.140), TRIG:ACQ:SOUR (p.141) to the factory default settings and newly starts the measurement by the INIT:ACQ (p.67), then queries only a single measured value of the latest measurement.
- READ newly starts the measurement by the INIT:ACQ (p.67), waits for a single measurement operation to complete and then queries the measured value.
- FETC does not wait for the measurement to finish. It queries only a single measured value of the latest measurement when the command is received.

## MEAS? / READ? / FETC?

Queries the measurement results.

### Command

```
:MEASure[:SCALar]?  
:READ[:SCALar]?  
:FETCh[:SCALar]?
```

### Response

NR3

Returns the responses in the order of voltage, current, power, elapsed time, integrated current, and integrated power.

## MEAS:ALL? / READ:ALL? / FETC:ALL?

Queries the measurement results.

Alias for MEAS? / READ? / FETC?.

### Command

```
:MEASure[:SCALar]:ALL?  
:READ[:SCALar]:ALL?  
:FETCh[:SCALar]:ALL?
```

### Response

NR3

Returns the responses in the order of voltage, current, power, elapsed time, integrated current, and integrated power.

## MEAS:CAP? / READ:CAP? / FETC:CAP?

Queries the measured current capacity (Ah).

### Command

```
:MEASure:CAPacity?  
:READ:CAPacity?  
:FETCh:CAPacity?
```

### Response

```
NR3  
Unit: AH
```

## MEAS:CURR? / READ:CURR? / FETC:CURR?

Queries the measured current (A).

### Command

```
:MEASure:CURRent[:DC]?  
:READ:CURRent[:DC]?  
:FETCh:CURRent[:DC]?
```

### Response

```
NR3  
Unit: A
```

## MEAS:ENER? / READ:ENER? / FETC:ENER?

Queries the measured power capacity (Wh).

### Command

```
:MEASure:ENERgy?  
:READ:ENERgy?  
:FETCh:ENERgy?
```

### Response

```
NR3  
Unit: WH
```

## MEAS:ETIM? / READ:ETIM ?/ FETC:ETIM?

Queries the measured elapsed time (s).

### Command

```
:MEASure:ETIMe?  
:READ:ETIMe?  
:FETCh:ETIMe?
```

### Response

```
NR3  
Unit: S
```

## MEAS:POW? / READ:POW? / FETC:POW?

Queries the measured power (W).

### Command

```
:MEASure:POWer[:DC]?  
:READ:POWer[:DC]?  
:FETCh:POWer[:DC]?
```

### Response

```
NR3  
Unit: W
```

## MEAS:VOLT? / READ:VOLT? / FETC:VOLT?

Queries the measured voltage (V).

### Command

```
:MEASure:VOLTagE[:DC]?  
:READ:VOLTagE[:DC]?  
:FETCh:VOLTagE[:DC]?
```

### Response

```
NR3  
Unit: V
```

# MEMory Command

Relates to the preset memory.

## MEM:CLE

Returns this product to its factory default settings.

Once this command has been executed, the system does not accept any commands until you restart PXB series. This command is disabled while the LUVF alarm is occurring.

### Command

```
:MEMory:CLEar
```

## MEM:REC

Recalls the settings from a desired preset memory.

You cannot execute in the following cases:

- While a sequence is running
- When setting VOLT:FUNC:MODE to other than DC or IR
- When setting CURR:FUNC:MODE to other than DC or DSE
- When setting POW:FUNC:MODE to other than DC or DSE

### Command

```
:MEMory:RECall[:IMMediate] <NRf>
```

### Parameter

Set value: 1 to 20

### Example

```
MEM:REC 2
```

## MEM:REC:CONF

Enables/disables the confirmation when the settings in a preset memory are recalled.

### Command

```
:MEMory:RECall:CONFirmation[:STATe] <boolean>
```

### Parameter

Set value:	ON (1)	Displays the confirmation screen when the settings of a preset memory are recalled. (default)
	OFF (0)	Immediately makes the settings in the preset memory take effect.

### Response

boolean

### Example

```
MEM:REC:CONF ON
```

## MEM:REC:PREV?

Queries the settings stored in a desired preset memory.

### Command

```
:MEMory:RECall:PREView? <NRf>
```

### Parameter

Set value: 1 to 20

### Response

Returns voltage <NR3>, Current (+) <NR3>, Current (-) <NR3>, Power (+) <NR3>, Power (-) <NR3>, SEAM voltage <NR3>, SEAM power (+) <NR3>, Internal resistance <NR3>, OVP <NR3>, UVP <NR3>, UVP enabled/disabled <boolean>, OCP (+) <NR3>, OCP (-) <NR3>, OPP (+) <NR3>, and OPP (-) <NR3> in the order mentioned and in a comma-separated format.

### Example

```
MEM:REC:PREV? 1
```

## MEM:SAVE

Saves the settings to a desired preset memory.

The settings to be saved are as follows:

VOLT (p.125), CURR (p.108), CURR:NEG (p.108), CURR:SEAM (p.118), POW (p.121), POW:NEG (p.121), POW:SEAM (p.123), RES:IR (p.124), VOLT:PROT (p.131), VOLT:PROT:LOW (p.132), VOLT:PROT:LOW:STAT (p.132), CURR:PROT (p.114), CURR:NEG:PROT (p.114), POW:PROT (p.122), POW:NEG:PROT (p.123)

### Command

```
:MEMory:SAVE[:IMMediate] <NRf>
```

### Parameter

Set value: 1 to 20

### Example

```
MEM:SAVE 2
```

# OUTPut Command

Relates to the output of the DC OUTPUT terminal.

## OUTP

Sets on/off of the output from the DC OUTPUT terminal.

If you set it to OUTPUT OFF while a sequence is running, a sequence will be forcefully stopped and the output will be turned off.

Command  
:OUTPut[:STATe] <boolean>  
:OUTPut[:STATe]?

### Parameter

Set value:	ON (1)	OUTPUT On
	OFF (0)	OUTPUT Off (default)

When set to OFF, an interval of 80 ms or more is required until it is turned ON next.  
Settings are reset to default when the \*RST command is sent.

### Response

boolean

### Example

OUTP ON

## OUTP:MSYN

Sends a sync signal of output ON or output OFF.

If you enter this command to any of the PXB series connected in synchronization, the PXB series in synchronization will be output ON/OFF simultaneously.

You cannot execute in the following cases:

- When not connected in synchronization
- While a sequence is running
- When setting CURR:FUNC:MODE (p. 109) or VOLT:FUNC:MODE (p. 126) to PULS

When the PXB series receiving the sync signal is in the following state, it is not synchronized.

- When setting OUTP:MSYN:ACC (p. 83) to OFF
- While a sequence is running
- When setting CURR:FUNC:MODE (p. 109) or VOLT:FUNC:MODE (p. 126) to PULS

### Command

```
:OUTPut:MSYNc[:IMMediate] <boolean>
```

### Parameter

Set value:	ON (1)	Sends a sync signal of output ON.
	OFF (0)	Sends a sync signal of output OFF.

### Response

boolean

### Example

```
OUTP:MSYN 1
```

## OUTP:MSYN:ACC

Enables or disables sending/receiving output ON/OFF sync signal (OUTP:MSYN).

When you clear the synchronization connection, it will be automatically set to OFF.

Cannot be set in the following cases:

- When not connected in synchronization
- While a sequence is running
- When setting CURR:FUNC:MODE ([p. 109](#)) or VOLT:FUNC:MODE ([p. 126](#)) to PULS

### Command

```
:OUTPut:MSYNc:ACCept[:STATe] <boolean>
:OUTPut:MSYNc:ACCept[:STATe]?
```

### Parameter

Set value:	ON (1)	Enabled
	OFF (0)	Disabled (default)

### Response

boolean

### Example

```
OUTP:MSYN:ACC ON
```

## OUTP:PON

Sets the output state when the power supply is turned on.

### Command

```
:OUTPut:PON[:STATe] <character>
:OUTPut:PON[:STATe]?
```

### Parameter

Set value:	SAFE	Starts with the output turned off. (default)
	AUTO	Starts with the output turned off when SYST:PON ( <a href="#">p. 150</a> ) is RST. If SYST:PON is RCL, the output state will be the state when the specified setup memory is called. If SYST:PON is set to AUTO, it will start in the output state it was in when the power supply was last turned off.
	FORCe	Starts with the output turned on.

### Response

character

### Example

```
OUTP:PON:STAT FORC
```

## OUTP:PROT:CLE

Clears LOW alarm.

### Command

```
:OUTPut:PROTection:CLEar
```

## OUTP:PROT:RSEN

Enables/disables Incorrect sensing connection detection (SENS).

When enabled, an alarm occurs, and the OUTPUT of the DC OUTPUT terminal turns off if the voltage difference between the DC OUTPUT terminal and the sensing terminal exceeds 10 % of the rated output voltage. This command functions when SYST:RSEN ([p.151](#)) is set to ON.

### Command

```
:OUTPut:PROTection:RSEnsing[:STATe] <boolean>
:OUTPut:PROTection:RSEnsing[:STATe]?
```

### Parameter

Set value:	ON (1)	Enabled (default)
	OFF (0)	Disabled

### Response

boolean

### Example

```
OUTP:PROT:RSEN ON
```

## OUTP:PROT:WDOG

Enables/disables communication error protection (WDOG).

### Command

```
:OUTPut:PROTection:WDOG[:STATe] <boolean>
:OUTPut:PROTection:WDOG[:STATe]?
```

### Parameter

Set value:	ON (1)	Enabled
	OFF (0)	Disabled (default)

### Response

boolean

### Example

```
OUTP:PROT:WDOG ON
```

## OUTP:PROT:WDOG:DEL

Sets the delay time before the communication error protection (WDOG) is activated.

When there have been no SCPI communications for the set delay time or longer, an alarm occurs, and the output of the OUTPUT terminal turns off.

To enable or disable the WDOG, OUTP:PROT:WDOG ([p.84](#)).

### Command

```
:OUTPut:PROTection:WDOG:DElay <Numeric>  
:OUTPut:PROTection:WDOG:DElay?
```

### Parameter

Set value: 1 to 3600 (The default value is 60)

Unit: S

### Response

NR3

### Example

```
OUTP:PROT:WDOG:DEL 3
```

# PROGram Command

It is a command that controls the program and the step.

A program is a collection of steps. Steps are executed in order one at a time, starting from step 1. The completion of the last step signifies that the program has been executed once.

You can create 30 programs at the maximum. The total number of steps for all programs combined can be 10000 steps at the maximum.

---

## NOTE

Programs with invalid parameters can be deleted, but cannot be edited and executed, and an error will be generated (-221 Settings conflict). In particular, be careful when changing the number of units in parallel operation.

---

## PROG:ALL:STEP:COUN?

Queries the total number of registered steps.

### Command

```
:PROG:ALL:STEPs:COUNT?
```

### Response

```
NR1
```

If there is no step created, 0 is returned.

## PROG:CAT?

Queries a list of registered programs.

### Command

```
:PROG:CATalog?
```

### Response

Returns a program name enclosed in quotation marks in a comma-separated format.

```
"<string>", "<string>", "<string>", ...
```

Returns " " when no program is registered.

## PROG:CHA:ADD

Adds a program to the chain.

When executing a program, it will be executed in the order of adding to the chain. Sequence cannot be executed when no program is registered in the chain.

If you wish to change the order of the program, clear all the programs registered in the chain in PROG:CHA:CLEAR (p.87), and then add them to the chain again.

---

### NOTE

Chain is unlocked in the following cases: Register the program in the chain again.

- When turning off the power supply of the PXB series
  - When creating a new program
  - When changing settings of/deleting a program registered in the chain or a program not registered in the chain
- 

### Command

```
:PROG:CHA:ADD "<string>"
```

### Parameter

Input the program name.

### Example

```
PROG:CHA:ADD "My test program"
```

## PROG:CHA:CAT?

Queries the list of programs registered in the chain.

### Command

```
:PROG:CHA:CATalog?
```

### Response

Returns a program name enclosed in quotation marks in a comma-separated format.

```
"<string>","<string>","<string>",...
```

Returns "" when no program is registered.

## PROG:CHA:CLEAR

Unlocks all programs registered in the chain.

### Command

```
:PROG:CHA:CLEAr
```

## PROG:CURR:FUNC:MODE

Sets the output mode of the program selected in PROG:NAME in CC mode.  
You cannot change the number of steps if there are two or more steps in the program.

---

### NOTE

Regardless of whether the program is registered in the chain or not, if the program settings are changed, the chain will be unlocked.

---

### Command

```
:PROG:[:SELeCted]:CURRent:FUNCTion:MODE <character>
:PROG:[:SELeCted]:CURRent:FUNCTion:MODE?
```

### Parameter

Set value:	DC	The current is controlled by the respective settings on the source and sink sides.
	DSEamless	Setting a positive value controls the current on the source side. Setting to a negative value controls the current on the sink side. Source/Sink operation of the PXB series switches seamlessly.

When a new program is created, it is set to DC.

### Response

character

### Example

```
PROG:CURR:FUNC:MODE DSE
```

## PROG:POW:FUNC:MODE

Sets the output mode of the program selected in PROG:NAME in CP mode.  
You cannot change the number of steps if there are two or more steps in the program.

### NOTE

Regardless of whether the program is registered in the chain or not, if the program settings are changed, the chain will be unlocked.

### Command

```
:PROG:NAME[:SElected]:POW:FUNCtion:MODE <character>
:PROG:NAME[:SElected]:POW:FUNCtion:MODE?
```

### Parameter

Set value:	DC	The current is controlled by the respective settings on the source and sink sides.
	DSEamless	Setting a positive value controls the current on the source side. Setting to a negative value controls the current on the sink side. Source/Sink operation of the PXB series.

When a new program is created, it is set to DC.

### Response

character

### Example

```
PROG:POW:FUNC:MODE DSE
```

## PROG:DEL

Deletes the program selected in PROG:NAME.

### NOTE

Regardless of whether the program is registered in the chain or not, if the program settings are changed, the chain will be unlocked.

### Command

```
:PROG:NAME[:SElected]:DELeTe
```

## PROG:DEL:ALL

Deletes all programs saved in the PXB series.

### Command

```
:PROG:NAME[:SElected]:DELeTe:ALL
```

## PROG:LOOP

Sets the repetition count of the program selected in PROG:NAME.

---

### NOTE

Regardless of whether the program is registered in the chain or not, if the program settings are changed, the chain will be unlocked.

---

### Command

```
:PROG:[:SElected]:LOOP[:COUNT] <NR1>  
:PROG:[:SElected]:LOOP[:COUNT]?
```

### Parameter

Set value:	1 to 100000	Repeat count
	INfinity	Infinite

When a new program is created, it is set to 1.

### Response

NR1  
Returns +0 when it is set to infinite.

### Example

```
PROG:LOOP 100
```

## PROG:NAME

Creates/selects/deselects a new program.

If the number of programs exceeds 30 or the total number of steps in all programs exceeds 10000, new programs cannot be created.

---

### NOTE

When a new program is created, the chain is unlocked.

---

### Command

```
:PROG:NAME[:SElected]:NAME "<string>"
:PROG:NAME[:SElected]:NAME?
```

### Parameter

Input the program name.

To create a new program, input a program name that is not saved in the PXB series. A new program will be created with the name of the input program, and it will be in a state where the program is selected.

To select a program, input a program name already saved in the PXB series.

To clear the program selection, enter "".

Naming convention: Alphabet characters A-Za-z, numbers 0-9, dot (.), comma (,), parentheses (), brackets [], braces </>, and (&), dollar (\$), hash (#), caret (^), percent (%), equal (=), hyphen (-), plus (+), underscore (\_), space ( ), case-sensitive, up to 32 characters.

Settings are reset to default when the \*RST command is sent. (Deselect)

### Response

string

### Example

```
PROG:NAME "My test program"
```

## PROG:REN

Changes the name of the program selected in PROG:NAME.

---

### NOTE

Regardless of whether the program is registered in the chain or not, if the program settings are changed, the chain will be unlocked.

---

### Command

```
:PROG:REN[:SElected]:REName "<string>"
```

### Parameter

Naming convention: Alphabet characters A-Za-z, numbers 0-9, dot (.), comma (,), parentheses (), brackets [], braces </>, and (&), dollar (\$), hash (#), caret (^), percent (%), equal (=), hyphen (-), plus (+), underscore (\_), space ( ), case-sensitive, up to 32 characters.

### Example

```
PROG:REN "Your test program"
```

## PROG:SAVE

Saves the program selected in PROG:NAME.

Saved programs will keep its settings even when the PXB series power supply is turned off.

### Command

```
:PROG:REN[:SElected]:SAVE
```

## PROG:STEP:COUN

Sets the number of steps to be registered to the program selected in PROG:NAME.

When a value greater than the number of steps at the present is specified, the shortfall in steps are added to the end with a default step. When a value less than the number of steps at the present is specified, the extra steps are removed from the end.

---

### NOTE

Regardless of whether the program is registered in the chain or not, if the program settings are changed, the chain will be unlocked.

---

#### Command

```
:PROG:NAME[:SElected]:STEPS:COUNt <NRf>
:PROG:NAME[:SElected]:STEPS:COUNt?
```

#### Parameter

Value: Number of steps 1 to 10000

The number of steps exceeding 10000 when all programs are totaled cannot be specified.

#### Response

NR1

#### Example

```
PROG:STEPS:COUN 10
```

## PROG:STEP<n>:CURR

Sets the current on the source side at the specified step of the program selected in PROG:NAME.

Use <n> to specify the step number.

---

### NOTE

Regardless of whether the program is registered in the chain or not, if the program settings are changed, the chain will be unlocked.

---

#### Command

```
:PROG:NAME[:SElected]:STEP<n>:CURRent <numeric>
:PROG:NAME[:SElected]:STEP<n>:CURRent?
```

#### Parameter <numeric>

Units: UA ( $\mu$ A), MA (mA) or A (A applies when this parameter is omitted.)

#### Response

NR3

#### Example

```
PROG:STEP1:CURR 10
```

## PROG:STEP<n>:CURR:NEG

Sets the current on the sink side at the specified step of the program selected in PROG:NAME.  
Use <n> to specify the step number.

---

### NOTE

Regardless of whether the program is registered in the chain or not, if the program settings are changed, the chain will be unlocked.

---

#### Command

```
:PROG:[:SElected]:STEP<n>:CURRent:NEGative <numeric>
:PROG:[:SElected]:STEP<n>:CURRent:NEGative?
```

#### Parameter <numeric>

Units: UA ( $\mu$ A), MA (mA) or A (A applies when this parameter is omitted.)

#### Response

NR3

#### Example

```
PROG:STEP1:CURR:NEG 10
```

## PROG:STEP<n>:CURR:SEAM

Sets the current of the seamless operation in CC mode at the specified step of the program selected in PROG:NAME.  
Use <n> to specify the step number. Setting a positive value controls the current on the source side. Setting to a negative value controls the current on the sink side. Source/Sink operation of the PXB series switches seamlessly.  
Enabled when DSE is set in PROG:CURR:FUNC:MODE ([p. 88](#)).

---

### NOTE

Regardless of whether the program is registered in the chain or not, if the program settings are changed, the chain will be unlocked.

---

#### Command

```
:PROG:[:SElected]:STEP<n>:CURRent:SEAMless <numeric>
:PROG:[:SElected]:STEP<n>:CURRent:SEAMless?
```

#### Parameter <numeric>

Units: UA ( $\mu$ A), MA (mA) or A (A applies when this parameter is omitted.)

#### Response

NR3

#### Example

```
PROG:STEP1:CURR:SEAM 10
```

## PROG:STEP<n>:POW

Sets the power on the source side at the specified step of the program selected in PROG:NAME.  
Use <n> to specify the step number.

---

### NOTE

Regardless of whether the program is registered in the chain or not, if the program settings are changed, the chain will be unlocked.

---

#### Command

```
:PROG:NAME[:SElected]:STEP<n>:POW <numeric>
:PROG:NAME[:SElected]:STEP<n>:POW?
```

#### Parameter <numeric>

Units: MW (mW), W, or KW (kW) (Wapplies when this parameter is omitted.)

#### Response

NR3

#### Example

```
PROG:STEP1:POW 10000
```

## PROG:STEP<n>:POW:NEG

Sets the power on the sink side at the specified step of the program selected in PROG:NAME.  
Use <n> to specify the step number.

---

### NOTE

Regardless of whether the program is registered in the chain or not, if the program settings are changed, the chain will be unlocked.

---

#### Command

```
:PROG:NAME[:SElected]:STEP<n>:POW:NEG <numeric>
:PROG:NAME[:SElected]:STEP<n>:POW:NEG?
```

#### Parameter <numeric>

Units: MW (mW), W, or KW (kW) (Wapplies when this parameter is omitted.)

#### Response

NR3

#### Example

```
PROG:STEP1:POW:NEG 10000
```

## PROG:STEP<n>:POW:SEAM

Sets the power of the seamless operation in CP mode at the specified step of the program selected in PROG:NAME. Use <n> to specify the step number. Setting a positive value controls the power on the source side. Setting to a negative value controls the power on the sink side. Source/Sink operation of the PXB series switches seamlessly. Enabled when DSE is set in PROG:POW:FUNC:MODE (p.89).

---

### NOTE

Regardless of whether the program is registered in the chain or not, if the program settings are changed, the chain will be unlocked.

---

#### Command

```
:PROG:[:SElected]:STEP<n>:POW:SEAMless <numeric>
:PROG:[:SElected]:STEP<n>:POW:SEAMless?
```

#### Parameter <numeric>

Units: MW (mW), W, or KW (kW) (W applies when this parameter is omitted.)

#### Response

NR3

#### Example

```
PROG:STEP1:POW:SEAM 10000
```

## PROG:STEP<n>:RES:IR

Sets the resistance at the specified step of the program selected in PROG:NAME. Use <n> to specify the step number.

---

### NOTE

Regardless of whether the program is registered in the chain or not, if the program settings are changed, the chain will be unlocked.

---

#### Command

```
:PROG:[:SElected]:STEP<n>:RESistance:IR <numeric>
:PROG:[:SElected]:STEP<n>:RESistance:IR?
```

#### Parameter <numeric>

Unit: OHM

#### Response

NR3

#### Command

```
PROG:STEP1:RES:IR 10
```

## PROG:STEP<n>:VOLT

Sets the voltage at the specified step of the program selected in PROG:NAME.  
Use <n> to specify the step number.

---

### NOTE

Regardless of whether the program is registered in the chain or not, if the program settings are changed, the chain will be unlocked.

---

### Command

```
:PROG:STEP<n>:VOLTage <numeric>
:PROG:STEP<n>:VOLTage?
```

### Parameter<numeric>

Units: MV (mV), V, or KV (kV) (V applies when this parameter is omitted.)

### Response

NR3

### Example

```
PROG:STEP1:VOLT 10
```

## PROG:STEP<n>:DEL

Deletes the specified step of the program selected in PROG:NAME.  
Use <n> to specify the step number. If the remained number of steps after a deletion becomes less than one, such deletion is not applicable.

---

### NOTE

Regardless of whether the program is registered in the chain or not, if the program settings are changed, the chain will be unlocked.

---

### Command

```
:PROG:STEP<n>:DELeTe
```

### Example

```
PROG:STEP8:DEL
```

## PROG:STEP<n>:DWEL

Sets the step execution time at the specified step of the program selected in PROG:NAME.  
Use <n> to specify the step number.

---

### NOTE

Regardless of whether the program is registered in the chain or not, if the program settings are changed, the chain will be unlocked.

---

### Command

```
:PROG:[:SElected]:STEP<n>:DWELl <numeric>  
:PROG:[:SElected]:STEP<n>:DWELl?
```

### Parameter <numeric>

Value: 0.001 seconds to 3600000.000 seconds (1000 hours)

Units: MS (milliseconds), S (seconds), MIN (minutes), HR (hours) (S applies when omitting)

When a new step is created, it is set to 1 second.

### Response

NR3

### Examples

```
PROG:STEP3:DWEL 1800
```

## PROG:STEP<n>:EDIT

Sets multiple setting items in a batch for the specified step of the program selected in PROG:NAME.  
Use <n> to specify the step number.

---

### NOTE

Regardless of whether the program is registered in the chain or not, if the program settings are changed, the chain will be unlocked.

---

### Command

```
:PROG:[:SElected]:STEP<n>:EDIT <item>
:PROG:[:SElected]:STEP<n>:EDIT?
```

### Parameter <item>

Specify in the following order in a comma-separated format.

OUTP<boolean>,RAMP<character>,DWEL<numeric>,FUNC:MODE<boolean>,OUTP:MODE:TRAN<boolean>,V  
OLT<numeric>,CURR<numeric>,CURR:NEG<numeric>,POW<numeric>,POW:NEG<numeric>,CURR:SEAM<nu  
meric>,POW:SEAM<numeric>,RES:IR<numeric>,TRIG:WAIT<character>,TRIG:GEN<character>

### Response

character

Returns each setting stated in the parameters in a comma-separated format.

### Example

```
PROG:STEP1:EDIT ON,IMM,1,DC,OFF,50,100,100,10000,10000,0,0,0,IMM,NONE
```

## PROG:STEP<n>:FUNC:MODE

Sets the output mode at the specified step of the program selected in PROG:NAME.  
Use <n> to specify the step number.

### NOTE

Regardless of whether the program is registered in the chain or not, if the program settings are changed, the chain will be unlocked.

### Command

```
:PROG:[:SElected]:STEP<n>:FUNction:MODE <character>
:PROG:[:SElected]:STEP<n>:FUNction:MODE?
```

### Parameter <character>

Set value:	DC	Controls by the respective settings on the source and sink sides.
	IR	Operates in the internal resistance function.
	CVSine	Operates in CV sine function.
	CCSine	Operates in CC sine function.

To set to CCSine, set PROG:Curr:FUNC:MODE to DSE.  
When a new step is created, it is set to DC.

### Response

boolean

### Example

```
PROG:STEP3:FUNC:MODE IR
```

## PROG:STEP<n>:INS

Copies the specified step of the program selected in PROG:NAME and inserts it into the previous step.  
Use <n> to specify the step number. Insertion cannot be performed if the total number of steps in all programs exceeds 10000.

### NOTE

Regardless of whether the program is registered in the chain or not, if the program settings are changed, the chain will be unlocked.

### Command

```
:PROG:[:SElected]:STEP<n>:INSert
```

### Example

```
PROG:STEP10:INS
```

## PROG:STEP<n>:OUTP

Sets output on/off at the specified step of the program selected in PROG:NAME.

Use <n> to specify the step number.

---

### NOTE

Regardless of whether the program is registered in the chain or not, if the program settings are changed, the chain will be unlocked.

---

### Command

```
:PROG:[:SElected]:STEP<n>:OUTPut <boolean>
```

```
:PROG:[:SElected]:STEP<n>:OUTPut?
```

### Parameter<boolean>

Set value:	ON(1)	Output ON
	OFF(0)	Output OFF

When a new step is created, it is set to OFF.

### Response

boolean

### Example

```
PROG:STEP3:OUTP ON
```

## PROG:STEP<n>:OUTP:MODE:TRAN

Sets whether to perform transition to the next step automatically or not when the operation mode changes at the specified step of the program selected in PROG:NAME.

Use <n> to specify the step number.

---

### NOTE

Regardless of whether the program is registered in the chain or not, if the program settings are changed, the chain will be unlocked.

---

### Command

```
:PROG:[:SELEcted]:STEP<n>:OUTPut:MODE:TRANsition <boolean>  
:PROG:[:SELEcted]:STEP<n>:OUTPut:MODE:TRANsition?
```

### Parameter <boolean>

Set value:	ON (1)	Performs transition to the next step automatically when the operation mode changes.
	OFF (0)	Continues execution of the step at the present even if the operation mode changes.

When a new step is created, it is set to OFF.

### Response

boolean

### Example

```
PROG:STEP3:OUTP:MODE:TRAN ON
```

## PROG:STEP<n>:RAMP

Sets the setting transition method at the specified step of the program selected in PROG:NAME.  
Use <n> to specify the step number.

---

### NOTE

Regardless of whether the program is registered in the chain or not, if the program settings are changed, the chain will be unlocked.

---

### Command

```
:PROGram[:SElected]:STEP<n>:RAMP <character>
:PROGram[:SElected]:STEP<n>:RAMP?
```

### Parameter <character>

Set value:	IMMEDIATE	Transition is performed in steps from the set value of the previous step.
	CV	Transition is performed in CV mode in slope from the set value of the previous step.
	CC	Transition is performed in CC mode in slope from the set value of the previous step.
	CP	Transition is performed in CP mode in slope from the set value of the previous step.

When a new step is created, it is set to IMMEDIATE.

### Response

character

### Example

```
PROG:STEP3:RAMP CV
```

## PROG:STEP<n>:TRIG:GEN

Sets whether to perform trigger output at the specified step of the program selected by PROG:NAME. Use <n> to specify the step number.

### NOTE

Regardless of whether the program is registered in the chain or not, if the program settings are changed, the chain will be unlocked.

### Command

```
:PROG:[:SELEcted]:STEP<n>:TRIGger:GENerate <character>
:PROG:[:SELEcted]:STEP<n>:TRIGger:GENerate?
```

### Parameter <character>

Set value:	NONE	Trigger is not output.
	DC	The general-purpose digital output signal is turned on during step execution. Enabled for channels in which IO:OUTP:FUNC is set to PTO.
	PULSe	A pulse signal is output from the general-purpose digital output when the step starts. Enabled for channels in which IO:OUTP:FUNC is set to PTO.

When a new step is created, it is set to NONE.

### Response

character

### Example

```
PROG:STEP3:TRIG:GEN PULS
```

## PROG:STEP<n>:TRIG:WAIT

Sets trigger wait at the specified step of the program selected in PROG:NAME.

Use <n> to specify the step number.

### NOTE

Regardless of whether the program is registered in the chain or not, if the program settings are changed, the chain will be unlocked.

### Command

```
:PROG:NAME[:SElected]:STEP<n>:TRIGger:WAIT <character>
```

```
:PROG:NAME[:SElected]:STEP<n>:TRIGger:WAIT?
```

### Parameter <character>

Set value:	IMMediate	Executes the step at the internal timing of the PXB series without waiting for trigger application.
	BUS	Executes the step at the input timing of a software trigger (*TRG) . The trigger is applied to both trigger systems: (1) sequence and step (TRANsient) and (2) measure (ACQuire).
	EXTernal	Executes the step when the TRAN is set in IO:INP:FUNC (p.71) and the trigger input is done.
	MSYNc	Executes the step at the timing that the MSync key is pressed on the front panel of the PXB series connected in synchronization. Or, executes the step at the timing that the synchronization instruction packet of TRIG:TRAN:MSYN (p.142) is input from a PC etc.

When a new step is created, it is set to IMMediate.

### Response

character

### Example

```
PROG:STEP3:TRIG:WAIT BUS
```

# SENSe Command

Relates to the recording time for measurement.

## SENS:APER

Sets the recording time period per measurement.

The average over the time period is recorded. Set a time shorter than TRIG:ACQ:INT:TIME (p. 140). Settings cannot be configured during measurement.

### Command

```
:SENSe[:DC]:APERture <Numeric>  
:SENSe[:DC]:APERture?
```

### Parameter

Set value: 0.0001 to 1.0 (The default value is 0.1)

Unit: S

Settings are reset to default when the \*RST command is sent.

### Response

NR3

### Example

```
SENS:APER 0.3
```

# SOURce:FUNction Command

Relates to the priority operation mode.

## FUNC:MODE

Sets the priority of the operation mode when the OUTPUT ON is selected. Settings cannot be performed while a sequence is running.

### Command

```
[ :SOURce ] :FUNction:MODE <character>  
[ :SOURce ] :FUNction:MODE?
```

### Parameter

Set value:	CV	Gives priority to the CV mode. (default)
	CC	Gives priority to the CC mode.
	CP	Gives priority to the CP mode.

Settings are reset to default when the \*RST command is sent.

### Response

character

### Example

```
FUNC:MODE CC
```

## FUNC:OFF:MODE

Sets the impedance when the output from the DC OUTPUT terminal is off.

### Command

```
[ :SOURce ] :FUNction:OFF:MODE <character>  
[ :SOURce ] :FUNction:OFF:MODE?
```

### Parameter

Set value:	HIGH	Set to high impedance. This setting makes the current flow less easily, thus preventing the sink current from batteries or other devices.
	LOW	Set to low impedance. This lowers the voltage so as to prevent voltage from remaining on the DC OUTPUT terminal. (default)

Settings are reset to default when the \*RST command is sent.

### Response

character

### Example

```
FUNC:OFF:MODE HIGH
```

# SOURce:CURRent Command

Relates to the current settings.

## CURR

Sets the current on the source side in the CC mode.

Enabled when CURR:FUNC:MODE is set to DC. Settings cannot be performed while a sequence is running.

### Command

```
[ :SOURce ] :CURRent [ :LEVel ] [ :IMMediate ] [ :AMPLitude ] <Numeric>  
[ :SOURce ] :CURRent [ :LEVel ] [ :IMMediate ] [ :AMPLitude ] ?
```

### Parameter

Units: UA ( $\mu$ A), MA (mA), or A (A applies when this parameter is omitted.)

Settings are reset to default when the \*RST command is sent. (MINimum)

### Response

NR3

Returns the unit in A.

### Example

```
CURR 12.0
```

## CURR:NEG

Sets the current in absolute value on the sink side in the CC mode.

Enabled when CURR:FUNC:MODE is set to DC. Settings cannot be performed while a sequence is running.

### Command

```
[ :SOURce ] :CURRent:NEGative [ :LEVel ] [ :IMMediate ] [ :AMPLitude ] <Numeric>  
[ :SOURce ] :CURRent:NEGative [ :LEVel ] [ :IMMediate ] [ :AMPLitude ] ?
```

### Parameter

Units: UA ( $\mu$ A), MA (mA), or A (A applies when this parameter is omitted.)

Settings are reset to default when the \*RST command is sent. (MINimum)

### Response

NR3

Returns the unit in A.

### Example

```
CURR:NEG 12.0
```

## CURR:FUNC:MODE

Sets the output function for CC mode.

Settings cannot be configured during output or while a sequence is running. Since it cannot be executed while writing I-V characteristic settings to the PXB series, an error is generated if the commands are sent sequentially.

### Command

```
[ :SOURce ] : CURRent : FUNCtion : MODE <character>
[ :SOURce ] : CURRent : FUNCtion : MODE ?
```

### Parameter

Set value:	DC	Operates in the normal CC mode. (default)
	IV	Enables the I-V characteristic function.
	PULSe	Enables the pulse function.
	SINE	Enables the sine function.
	EXTernal	Use an external control.
	DSEamless	Setting CURR:SEAM ( <a href="#">p. 118</a> ) to a positive value controls the current on the source side. Setting to a negative value controls the current on the sink side. The PXB series unit seamlessly switches between source and sink operation.
	ESEamless	The current setting is controlled by an analog input from an external control. When the external voltage is set to positive, the source side current is controlled. When the external voltage is set to negative, the sink side current is controlled. When an external voltage with a sine wave having zero-crossing, etc. is selected, the PXB series unit seamlessly switches between source and sink operation.

Settings are reset to default when the \*RST command is sent.

### Response

character

### Example

```
CURR:FUNC:MODE EXT
```

## CURR:IV:CAT?

Queries voltage and current for all point indexes of the I-V characteristic in CC mode.

### Command

```
[ :SOURce ] : CURRent : IV : CATalog ?
```

### Response

Returns in the order from voltage to current in comma-separated NR3 format.

### Response example

When the first point value is 0 V and 0 A and the second point value is 30 V and 5 A

```
0.00000E+00,0.00000E+00,3.00000E+01,5.00000E+00
```

## CURR:IV:CLE

Returns the I-V characteristics in CC mode to the factory default setting.

Cannot be executed during output or while a sequence is running. Since it cannot be executed while writing I-V characteristic settings to the PXB series, an error is generated if the commands are sent sequentially.

### Command

```
[ :SOURce ] :CURRent :IV :CLEar
```

## CURR:IV:COUN

Sets the number of data points of I-V characteristics in CC mode.

In the I-V characteristic function, the point indicated by combining voltage and current is counted as one point. When a value greater than the number of data at present is specified, copy the last current and voltage and add them at the end.

When a value less than the number of data at present is specified, the extra current and voltage combinations are removed from the end.

Cannot be executed during output and while a sequence is running. Since it cannot be executed while writing I-V characteristic settings to the PXB series, an error is generated if the commands are sent sequentially.

### Command

```
[ :SOURce ] :CURRent :IV :COUNt <NRf>
```

```
[ :SOURce ] :CURRent :IV :COUNt?
```

### Parameter

Set value: 3 to 100 (Default: 3)

Settings are reset to default when the \*RST command is sent.

### Response

NR1

### Example

```
CURR:IV:COUN 30
```

## CURR:IV:DATA

Sets the entire I-V characteristics in CC mode in the binary block data format.

As the data of the entire I-V characteristics is set at one time, you do not need to perform initialization with CURR:IV:CLE or set the number of points with CURR:IV:COUN in advance.

The CURR:IV:COUN value is changed depending on the block data setting.

Settings cannot be configured during output and while a sequence is running. Since it cannot be executed while writing I-V characteristic settings to the PXB series, an error is generated if the commands are sent sequentially.

### Command

```
[ :SOURce ] :CURRent:IV:DATA #<length-width><length><data>
[ :SOURce ] :CURRent:IV:DATA?
```

### Parameter <length-width>

Number of digits of <length>

### Parameter <length>

Byte length of <data>

### Parameter <data>

Expresses the voltage and current data in a binary 4 byte integer. Expresses one point with 4 bytes (8 digits), and describes a pair of voltage and current values in response to one point. Each value is in little-endian format, and the unit is written using  $\mu\text{V}$  and  $\mu\text{A}$ .

Describe the voltage as follows: If you specify any other values, an error is returned.

- Set the first voltage to 0 V.
- Set the last voltage to the maximum settable value.
- Set the voltage equal to or greater than previous point.

The maximum settable value of voltage is 52.5 V for PXB20K-50, 262.5 V for PXB20K-250, 525 V for PXB20K-500, 1050 V for PXB20K-1000, and 1575 V for PXB20K-1500.

**Example**

If you set the combination of “0 V, 0 A,” “1 V, 0.1 A,” and “1575 V, 0.1 A” with PXB20K-1500, the byte length of <data> would be 24. Send the following command in binary. During a binary transfer, we do not recommend concatenating other commands. Terminate with LF.

```
CURR:IV:DATA 23343030323400000000000000000040420F00A0860100C097E05DA08601000A
```

How to create parameters is explained below.

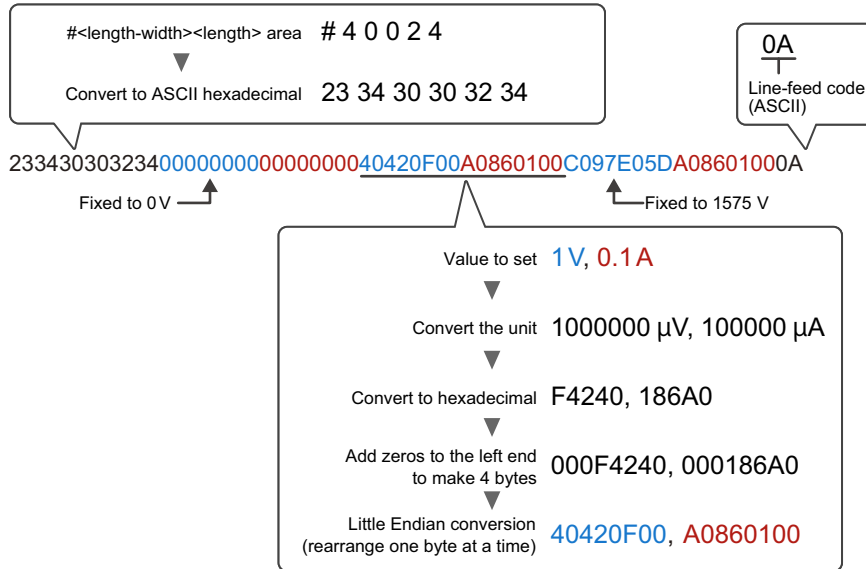

**Response**

block  
 #<length-width><length><data> is returned.

**Response example**

In the case of the combination “0 V, 0 A,” “1 V, 0.1 A,” and “1575 V, 0.1 A,” the following response is returned.  
 23343030323400000000000000000040420F00A0860100C097E05DA08601000A

The “233430303234” in the beginning, when converted into hexadecimal ASCII character code every two digits, becomes “#40024.” This indicates that <length-width> is 4, and <length> is 0024.

## CURR:IV:MAP<n>

Sets the voltage and current for the specified parts (point index) of the I-V characteristics in CC mode.

Replace <n> with the point index of the I-V characteristic for setting. The setting range of the point index is values from 1 to CURR:IV:COUN (p.110).

Cannot be executed during output and while a sequence is running. Since it cannot be executed while writing I-V characteristic settings to the PXB series, an error is generated if the commands are sent sequentially.

### Command

```
[ :SOURce ] :CURRent:IV:MAP<n> <voltage>,<current>
[ :SOURce ] :CURRent:IV:MAP<n>? <index>
```

### Parameter <voltage>

Specifies the voltage at the designated point index in numeric.

Units: MV (mV), V, or KV (kV) (V applies when this parameter is omitted.)

Describe the voltage as follows: If you specify any other values, an error is returned.

- Set the first voltage to 0 V.
- Set the last voltage to the maximum settable value.
- Set the voltage equal to or greater than previous point.

The maximum settable value of voltage is 52.5 V for PXB20K-50, 262.5 V for PXB20K-250, 525 V for PXB20K-500, 1050 V for PXB20K-1000, and 1575 V for PXB20K-1500.

### Parameter <current>

Specifies the current at the designated point index in numeric.

Units: UA (µA), MA (mA), A (A applies when this parameter is omitted.)

### Response

Returns the voltage [V] and current [A] at the designated point index in comma-separated in NR3 format.

### Example

```
CURR:IV:MAP2 5.0,1.0
```

## CURR:IV:MAP<n>:DEL

Deletes the voltage and current for the specified parts (point index) of the I-V characteristics in CC mode.

Replace <n> with the point index of the I-V characteristic for setting. The setting range of the point index is values from 2 to (CURR:IV:COUN (p.110) - 1).

Cannot set a value where the point index after deleting is 3 or less.

The first point index and the last point index cannot be deleted. Cannot be executed during output and while a sequence is running. Since it cannot be executed while writing I-V characteristic settings to the PXB series, an error is generated if the commands are sent sequentially.

### Command

```
[ :SOURce ] :CURRent:IV:MAP<n>:DELeTe <NRf>
```

### Example

```
CURR:IV:MAP5:DEL
```

## CURR:IV:MAP<n>:INS

Inserts a point index at the specified section of the I-V characteristics in CC mode.

Replace <n> with the point index of the I-V characteristic for setting. The setting range of the point index is values from 1 to CURR:IV:COUN (p.110).

Cannot set a value where the point index after inserting is above 100 points.

A value the same as the specified point index is inserted. Settings cannot be configured during output and while a sequence is running. Since it cannot be executed while writing I-V characteristic settings to the PXB series, an error is generated if the commands are sent sequentially.

### Command

```
[SOURce:]CURRent:IV:MAP<n>:INSert <NRf>
```

### Example

```
CURR:IV:MAP5:INS
```

## CURR:PROT

Sets the threshold current for the overcurrent protection (OCP) on the source side.

### Command

```
[ :SOURce]:CURRent:PROTection[:LEVel] <Numeric>  
[:SOURce]:CURRent:PROTection[:LEVel]?
```

### Parameter

Units: UA ( $\mu$ A), MA (mA), or A (A applies when this parameter is omitted.)

Settings are reset to default when the \*RST command is sent. (MAXimum)

### Response

```
NR3
```

### Example

```
CURR:PROT 15.0
```

## CURR:NEG:PROT

Sets the threshold current in absolute value for the overcurrent protection (OCP) on the sink side.

### Command

```
[ :SOURce]:CURRent:NEGative:PROTection[:LEVel] <Numeric>  
[:SOURce]:CURRent:NEGative:PROTection[:LEVel]?
```

### Parameter

Units: UA ( $\mu$ A), MA (mA), A (A applies when this parameter is omitted.)

Settings are reset to default when the \*RST command is sent. (MAXimum)

### Response

```
NR3
```

### Example

```
CURR:NEG:PROT 15.0
```

## CURR:PROT:DEL

Sets the delay time after the current exceeding the threshold for the overcurrent protection (OCP) has been detected before the OCP is activated.

### Command

```
[ :SOURce ] :CURRent:PROTection:DELAy <Numeric>
[ :SOURce ] :CURRent:PROTection:DELAy?
```

### Parameter

Set value: 0.0 to 2.0 (The default value is MINimum)

Unit: S

### Response

NR3

### Example

```
CURR:PROT:DEL 1.5
```

## CURR:PULS:DCYC

Sets the duty cycle of the pulse function in CC mode.  
Settings cannot be performed while a sequence is running.

### Command

```
[ :SOURce ] :CURRent:PULSe:DCYCLE <numeric>
[ :SOURce ] :CURRent:PULSe:DCYCLE?
```

### Parameter

Set value: 2.5 to 97.5 (Resolution: 0.01, Default: MINimum)

Unit: PCT

Settings are reset to default when the \*RST command is sent.

### Response

NR3

### Example

```
CURR:PULS:DCYC 40
```

## CURR:PULS:FREQ

Sets the frequency of the pulse function in CC mode.  
Settings cannot be performed while a sequence is running.

### Command

```
[ :SOURce ] :CURRent :PULSe :FREQuency <numeric>
[ :SOURce ] :CURRent :PULSe :FREQuency ?
```

### Parameter

Set value: 1 Hz to 1000 Hz (Default: 1 Hz)  
Unit: HZ  
Resolution: Varies depending on the frequency before the setting.  
1 Hz to 10 Hz: 0.01 Hz  
10 Hz to 100 Hz: 0.1 Hz  
100 to 1000 Hz: 1 Hz

Settings are reset to default when the \*RST command is sent.

### Response

NR3

### Example

```
CURR:PULS:FREQ 1
```

## CURR:PULS:HIGH

For the pulse function in CC mode, sets the high level current.  
Cannot be set for the value less than the set value of CURR:PULS:LOW. Settings cannot be performed while a sequence is running.

### Command

```
[ :SOURce ] :CURRent :PULSe :HIGH <numeric>
[ :SOURce ] :CURRent :PULSe :HIGH ?
```

### Parameter

Units: UA ( $\mu$ A), MA (mA), A (A applies when this parameter is omitted.)  
Settings are reset to default when the \*RST command is sent. (0 A)

### Response

NR3  
Returns the unit in A.

### Example

```
CURR:PULS:HIGH 13.0
```

## CURR:PULS:LOW

For the pulse function in CC mode, sets the low level current.

Cannot be set for the value above the set value of CURR:PULS:HIGH. Settings cannot be performed while a sequence is running.

### Command

```
[ :SOURce ] :CURRent :PULSe :LOW <numeric>
[ :SOURce ] :CURRent :PULSe :LOW?
```

### Parameter

Units: UA ( $\mu$ A), MA (mA), A (A applies when this parameter is omitted.)

Settings are reset to default when the \*RST command is sent. (0 A)

### Response

NR3

Returns the unit in A.

### Example

```
CURR:PULS:LOW 13.0
```

## CURR:RESP

Sets the response in the CC mode.

Settings cannot be performed while a sequence is running.

### Command

```
[ :SOURce ] :CURRent :RESPonce [ :SPEed ] <NRf>
[ :SOURce ] :CURRent :RESPonce [ :SPEed ] ?
```

### Parameter

Set value:	SLOW	Normal
	FAST	High-speed (default)

Settings are reset to default when the \*RST command is sent.

### Response

character

### Example

```
CURR:RESP FAST
```

## CURR:SEAM

Sets the current for seamless operation.

This is enabled when CURR:FUNC:MODE (p. 109) is set to DSEamless.

Settings cannot be performed while a sequence is running.

### Command

```
[ :SOURce ] :CURRent [ :LEVel ] :SEAMless <Numeric>
[ :SOURce ] :CURRent [ :LEVel ] :SEAMless?
```

### Parameter

The maximum value is 105 % of the rated current, and the minimum value is -105 % of the rated current.

Units: UA ( $\mu$ A), MA (mA), or A (A applies when this parameter is omitted.)

Settings are reset to default when the \*RST command is sent. (0 A)

### Response

NR3

Returns the unit in A.

### Example

```
CURR:SEAM 12.0
```

## CURR:SINE:AMPL

Sets the amplitude of the CC mode sine function (peak-to-peak value).

Cannot be set in the following cases:

- While a sequence is running
- When the total of the set value of CURR:SINE:AMPL  $\div$  2 and the set value of CURR:SINE:OFFS is outside the setting range (-105 % to +105 % of the rated voltage).

### Command

```
[ :SOURce ] :CURRent [ :LEVel ] :SINE:AMPLitude <numeric>
[ :SOURce ] :CURRent [ :LEVel ] :SINE:AMPLitude?
```

### Parameter

The minimum value is 0 A and the maximum value is 210 % of the rated current. (Default: 0 A)

Units: UA ( $\mu$ A), MA (mA), A (A applies when this parameter is omitted.)

Settings are reset to default when the \*RST command is sent.

### Response

NR3

### Example

```
CURR:SINE:AMPL 12.0
```

## CURR:SINE:FREQ

Sets the frequency of the sine function in CC mode.  
Settings cannot be performed while a sequence is running.

### Command

```
[ :SOURce ] :CURRent :SINE :FREQuency <numeric>
[ :SOURce ] :CURRent :SINE :FREQuency?
```

### Parameter

Set value: 1 Hz to 1000 Hz (Default: 1 Hz)  
Unit: HZ  
Resolution: Varies depending on the frequency before the setting.  
1 Hz to 10 Hz: 0.2 Hz  
10 Hz to 100 Hz: 2 Hz  
100 to 1000 Hz: 20 Hz

Settings are reset to default when the \*RST command is sent.

### Response

NR3

### Example

```
CURR:SINE:FREQ 50
```

## CURR:SINE:OFFS

Sets the correction value of the sine function waveform in CC mode.  
Cannot be set in the following cases:

- While a sequence is running
- When the total of the set value of CURR:SINE:AMPL ÷ 2 and the set value of CURR:SINE:OFFS is outside the setting range (–105 % to +105 % of the rated voltage).

### Command

```
[ :SOURce ] :CURRent :SINE :OFFSet <numeric>
[ :SOURce ] :CURRent :SINE :OFFSet?
```

### Parameter

The minimum value is –105 % of the rated power and the maximum value is 105 % of the rated power. (Default: 0 A)

Units: UA (µA), MA (mA), A (A applies when this parameter is omitted.)

Settings are reset to default when the \*RST command is sent.

### Response

NR3

### Example

```
CURR:SINE:OFFS 16.0
```

## CURR:SLEW

Sets the slew rate in the CC mode.

You cannot change the settings while the output of the OUTPUT terminal is on.

### Command

```
[ :SOURce ] :CURRent :SLEW <Numeric>
[ :SOURce ] :CURRent :SLEW?
```

### Parameter

Model name	Set value [A/ms]
PXB20K-50	0.2/2/20/200/400 (Default: 200)
PXB20K-250	0.05/0.5/5/50/100 (Default: 50)
PXB20K-500	0.03/0.3/3/30/60 (Default: 30)
PXB20K-1000	0.015/0.15/1.5/15/30 (Default: 15)
PXB20K-1500	0.0075/0.075/0.75/7.5/15 (Default: 7.5)

Units: UA ( $\mu$ A), MA (mA), or A (A applies when this parameter is omitted.)

The units given above are for convenience. The units that are actually applied are  $\mu$ A/ms, mA/ms, and A/ms. If a value other than the above is specified, the adjustable value with the smallest margin equal to or less than the specified value is applied.

Settings are reset to default when the \*RST command is sent.

## NOTE

Setting the slew rate to the maximum value will actually result in a slew rate of 25 % or more of the rated value. For example, setting the 15 A/ms of PXB20K-1500 will result in a slew rate of 7.5 A/ms or more. It can be used when you need the fastest operation, but note the following points.

- Overshoot will occur more easily due to the faster response time.
- OCP alarms may occur when the OCP setting is 20 % or less of the rating. It is because the charge current of the internal capacitor is detected during output even if the DUT is not connected.

### Response

NR3

### Example

```
CURR:SLEW 0.3
```

# SOURce:POWer Command

Relates to the power settings.

## POW

Sets the power on the source side in the CP mode.

Enabled when POW:FUNC:MODE is set to DC. Settings cannot be performed while a sequence is running.

### Command

```
[ :SOURce ] :POWer [ :LEVel ] [ :IMMediate ] [ :AMPLitude ] <Numeric>  
[ :SOURce ] :POWer [ :LEVel ] [ :IMMediate ] [ :AMPLitude ] ?
```

### Parameter

Units: MW (mW), W, or KW (kW) (W applies when this parameter is omitted.)

Settings are reset to default when the \*RST command is sent. (MAXimum)

### Response

NR3 [W]

### Example

```
POW 600.0
```

## POW:NEG

Sets the power in absolute value on the sink side in the CP mode.

Enabled when POW:FUNC:MODE is set to DC. Settings cannot be performed while a sequence is running.

### Command

```
[ :SOURce ] :POWer:NEGative [ :LEVel ] [ :IMMediate ] [ :AMPLitude ] <Numeric>  
[ :SOURce ] :POWer:NEGative [ :LEVel ] [ :IMMediate ] [ :AMPLitude ] ?
```

### Parameter

Units: MW (mW), W, or KW (kW) (W applies when this parameter is omitted.)

Settings are reset to default when the \*RST command is sent. (MAXimum)

### Response

NR3

### Example

```
POW:NEG 600.0
```

## POW:FUNC:MODE

Sets the output function for CP mode.

Settings cannot be configured during output and while a sequence is running.

### Command

```
[ :SOURce ] :POWer:FUNcTion:MODE <character>
[ :SOURce ] :POWer:FUNcTion:MODE?
```

### Parameter

Set value:	DC	Operates in the normal CP mode. (default)
	EXTErnal	Use an external control.
	DSEamless	Setting POW:SEAM ( <a href="#">p. 123</a> ) to a positive value controls the power on the source side. Setting to a negative value controls the power on the sink side. The PXB series unit seamlessly switches between source and sink operation.
	ESEamless	The power setting is controlled by an analog input from an external control. When the external voltage is set to positive, the source side power is controlled. When the external voltage is set to negative, the sink side power is controlled. When an external voltage with a sine wave having zero-crossing, etc. is selected, the PXB series unit seamlessly switches between source and sink operation.

Settings are reset to default when the \*RST command is sent.

### Response

character

### Example

```
POW:FUNC:MODE EXT
```

## POW:PROT

Sets the threshold power for the overpower protection (OPP) on the source side.

### Command

```
[ :SOURce ] :POWer:PROTEction[:LEVel] <Numeric>
[ :SOURce ] :POWer:PROTEction[:LEVel]?
```

### Parameter

Units: MW (mW), W, or KW (kW) (W applies when this parameter is omitted.)

Settings are reset to default when the \*RST command is sent. (MAXimum)

### Response

NR3

### Example

```
POW:PROT 2000.0
```

## POW:NEG:PROT

Sets the threshold power in absolute value for the overpower protection (OPP) on the sink side.

### Command

```
[ :SOURce ] :POWer:NEGative:PROTection[:LEVel] <Numeric>
[ :SOURce ] :POWer:NEGative:PROTection[:LEVel] ?
```

### Parameter

Units: MW (mW), W, or KW (kW) (W applies when this parameter is omitted.)

Settings are reset to default when the \*RST command is sent. (MAXimum)

### Response

NR3

### Example

```
POW:NEG:PROT 2000.0
```

## POW:SEAM

Sets the power for seamless operation.

This is enabled when POW:FUNC:MODE ([p.122](#)) is set to DSEamless.

Settings cannot be performed while a sequence is running.

### Command

```
[ :SOURce ] :POWer[:LEVel]:SEAMless <Numeric>
[ :SOURce ] :POWer[:LEVel]:SEAMless ?
```

### Parameter

The maximum value is 105 % of the rated power, and the minimum value is -105 % of the rated power.

Units: MW (mW), W, or KW (kW) (W applies when this parameter is omitted.)

Settings are reset to default when the \*RST command is sent. (MAXimum)

### Response

NR3

### Example

```
POW:SEAM 600.0
```

# SOURce:RESistance Command

Relates to the resistance settings.

## RES:IR

Sets the internal resistance value.

To enable the internal resistance function, set VOLT:FUNC:MODE (p. 126) to IR.

Settings cannot be performed while a sequence is running.

### Command

```
[ :SOURce ] :RESistance :IR [ :LEVel ] [ :IMMediate ] [ :AMPLitude ] <NRf>  
[ :SOURce ] :RESistance :IR [ :LEVel ] [ :IMMediate ] [ :AMPLitude ] ?
```

### Parameter

Units: OHM ( $\Omega$ ) or KOHM (k $\Omega$ ) (OHM applies when this parameter is omitted.)

Settings are reset to default when the \*RST command is sent. (MINimum)

### Response

NR3

### Example

```
RES:IR 0.16
```

# SOURce:VOLTage Command

Relates to the voltage settings.

## VOLT

Sets the voltage in CV mode.

Enabled when VOLT:FUNC:MODE is set to DC or IR. Settings cannot be performed while a sequence is running.

### Command

```
[ :SOURce ] :VOLTage [ :LEVel ] [ :IMMediate ] [ :AMPLitude ] <Numeric>  
[ :SOURce ] :VOLTage [ :LEVel ] [ :IMMediate ] [ :AMPLitude ] ?
```

### Parameter

Units: MV (mV), V, or KV (kV) (V applies when this parameter is omitted.)

Settings are reset to default when the \*RST command is sent. (0 V)

### Response

NR3 [V]

### Example

```
VOLT 20.0
```

## VOLT:FUNC:MODE

Sets the output function for CV mode.

Settings cannot be configured during output and while a sequence is running.

### Command

```
[ :SOURce ] :VOLTage:FUNCTion:MODE <NRf>
[ :SOURce ] :VOLTage:FUNCTion:MODE?
```

### Parameter

Set value:	DC	Operates in the normal CV mode. (default)
	IR	Enables the internal resistance function.
	PULSe	Enables the pulse function.
	SINE	Enables the sine function.
	IV	Enables the I-V characteristic function.
	EXTeRnal	Use an external control.

Settings are reset to default when the \*RST command is sent.

### Response

character

### Example

```
VOLT:FUNC:MODE EXT
```

## VOLT:IV:CAT?

Queries voltage and current for all point indexes of the I-V characteristic in CV mode.

### Command

```
[ :SOURce ] :VOLTage:IV:CATalog?
```

### Response

Returns in the order from voltage to current in comma-separated NR3 format.

### Response example

When the first point value is 0 V and 0 A and the second point value is 30 V and 5 A

```
0.00000E+00,0.00000E+00,3.00000E+01,5.00000E+00
```

## VOLT:IV:CLE

Returns the I-V characteristics in CV mode to the factory default setting.

Settings cannot be configured during output and while a sequence is running. Since it cannot be executed while writing I-V characteristic settings to the PXB series, an error is generated if the commands are sent sequentially.

### Command

```
[ :SOURce ] :VOLTage:IV:CLEar
```

## VOLT:IV:COUN

Sets the number of data points of I-V characteristics in CV mode.

In the I-V characteristic function, the point indicated by combining voltage and current is counted as one point. When a value greater than the number of data at present is specified, copy the last current and voltage and add them at the end.

When a value less than the number of data at present is specified, the extra current and voltage combinations are removed from the end.

Settings cannot be configured during output and while a sequence is running. Since it cannot be executed while writing I-V characteristic settings to the PXB series, an error is generated if the commands are sent sequentially.

### Command

```
[ :SOURce ] :VOLTage:IV:COUNT <NRf>
```

```
[ :SOURce ] :VOLTage:IV:COUNT?
```

### Parameter

Set value: 3 to 100 (Default: 3)

Settings are reset to default when the \*RST command is sent.

### Response

NR3

### Example

```
VOLT:IV:COUN 30
```

## VOLT:IV:DATA

Sets the entire I-V characteristics in CV mode in the binary block data format.

As the data of the entire I-V characteristics is set at one time, you do not need to perform initialization with VOLT:IV:CLE or set the number of points with VOLT:IV:COUN in advance.

The VOLT:IV:COUN value is changed depending on the block data settings.

Settings cannot be configured during output and while a sequence is running. Since it cannot be executed while writing I-V characteristic settings to the PXB series, an error is generated if the commands are sent sequentially.

### Command

```
[ :SOURce ] :VOLTage:IV:DATA #<lengthwidth><length><data>
[ :SOURce ] :VOLTage:IV:DATA?
```

### Parameter <length-width>

Number of digits of <length>

### Parameter <length>

Byte length of <data>

### Parameter <data>

Expresses the voltage and current data in a binary 4 byte integer. Expresses one point with 4 bytes (8 digits), and describes a pair of voltage and current values in response to one point. Each value is in little-endian format, and the unit is written using  $\mu\text{V}$  and  $\mu\text{A}$ .

Describe the current as follows: If you specify any other values, an error is returned.

- Set the first current to minimum settable value.
- Set the last current to the maximum settable value.
- Set the current equal to or greater than previous point.

The minimum settable value of current is -840 A for PXB20K-50, -210 A for PXB20K-250, -126 A for PXB20K-500, -63 A for PXB20K-1000, and -31.5 A for PXB20K-1500.

The maximum settable value of current is 840 A for PXB20K-50, 210 A for PXB20K-250, 126 A for PXB20K-500, 63 A for PXB20K-1000, and 31.5 A for PXB20K-1500.

### Example

If you set the combination of “0 V, -63 A,” “1 V, 0.1 A,” and “1575 V, 63 A” with PXB20K-1500, the byte length of <data> would be 24. Send the following command in binary. During a binary transfer, we do not recommend concatenating other commands. Terminate with LF.

VOLT:IV:DATA 2334303032340000000040B23EFC40420F00A0860100C097E05DC04DC1030A

How to create parameters is explained below.

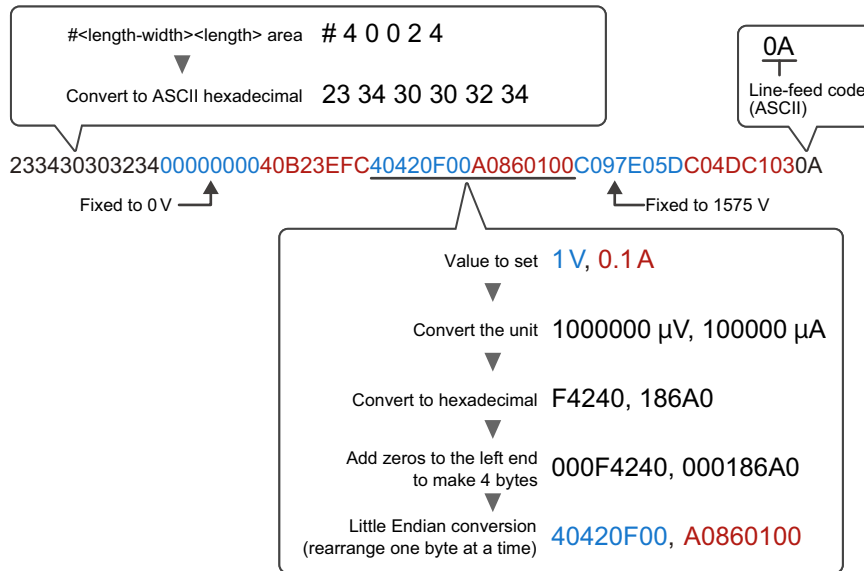

### Response

block

#<length-width><length><data> is returned.

### Response example

In the case of the combination “0 V, -63 A,” “1 V, 0.1 A,” and “1575 V, 63 A,” the following response is returned.

2334303032340000000040B23EFC40420F00A0860100C097E05DC04DC1030A

The “233430303234” in the beginning, when converted into hexadecimal ASCII character code every two digits, becomes “#40024.” This indicates that <length-width> is 4, and <length> is 0024.

## VOLT:IV:MAP<n>

Sets the voltage and current for the specified parts (point index) of the I-V characteristics in CV mode.

Replace <n> with the point index of the I-V characteristic for setting. The setting range of the point index is values from 1 to VOLT:IV:COUN (p.127).

Settings cannot be configured during output and while a sequence is running. Since it cannot be executed while writing I-V characteristic settings to the PXB series, an error is generated if the commands are sent sequentially.

### Command

```
[ :SOURce ] :VOLTage:IV:MAP<n> <voltage>, <current>
[ :SOURce ] :VOLTage:IV:MAP<n>?
```

### Parameter <voltage>

Specifies the voltage at the designated point index in numeric.

Units: UV ( $\mu$ V), MV (mV), V (applies when this parameter is omitted.)

### Parameter <current>

Specifies the current at the designated point index in numeric.

Units: UA ( $\mu$ A), MA (mA) or A (A applies when this parameter is omitted.)

Describe the current as follows: If you specify any other values, an error is returned.

- Set the first current to 0 A.
- Set the last current to the maximum settable value.
- Set the current equal to or greater than previous point.

The maximum settable value of current is 840 A for PXB20K-50, 210 A for PXB20K-250, 126 A for PXB20K-500, 63 A for PXB20K-1000, and 31.5 A for PXB20K-1500.

### Response

Returns the voltage [V] and current [A] at the designated point index in comma-separated NRf format.

### Example

```
VOLT:IV:MAP2 5.0,1.0
```

## VOLT:IV:MAP<n>:DEL

Deletes the voltage and current for the specified parts (point index) of the I-V characteristics in CV mode.

Replace <n> with the point index of the I-V characteristic for setting. The setting range of the point index is values from 2 to (VOLT:IV:COUN (p.127) - 1).

Cannot set a value where the point index after deleting is 3 or less.

The first point index and the last point index cannot be deleted. Settings cannot be configured during output and while a sequence is running. Since it cannot be executed while writing I-V characteristic settings to the PXB series, an error is generated if the commands are sent sequentially.

### Command

```
[ :SOURce ] :VOLTage:IV:MAP<n>:DELeTe
```

### Example

```
VOLT:IV:MAP5:DEL
```

## VOLT:IV:MAP<n>:INS

Inserts a point index at the specified section of the I-V characteristics in CV mode.

Replace <n> with the point index of the I-V characteristic for setting. The setting range of the point index is values from 1 to VOLT:IV:COUN (p. 127).

Cannot set a value where the point index after inserting is above 100 points.

Settings cannot be configured during output and while a sequence is running. Since it cannot be executed while writing I-V characteristic settings to the PXB series, an error is generated if the commands are sent sequentially.

### Command

```
[ :SOURce ] :VOLTage:IV:MAP<n>:INSert <NRf>
```

### Example

```
VOLT:IV:MAP5:INS
```

## VOLT:PROT

Sets the voltage of overvoltage protection (OVP).

### Command

```
[ :SOURce ] :VOLTage:PROTection[:LEVel][:UPPer] <Numeric>
[ :SOURce ] :VOLTage:PROTection[:LEVel][:UPPer] ?
```

### Parameter

Units: MV (mV), V, or KV (kV) (V applies when this parameter is omitted.)

Settings are reset to default when the \*RST command is sent. (MAXimum)

### Response

NR3

### Example

```
VOLT:PROT 500
```

## VOLT:PROT:LOW

Sets the voltage of undervoltage protection (UVP).

To enable/disable UVP, VOLT:PROT:LOW:STAT ([p. 132](#)).

### Command

```
[ :SOURce ]:VOLTage:PROTection[:LEVel]:LOWer <Numeric>
[ :SOURce ]:VOLTage:PROTection[:LEVel]:LOWer?
```

### Parameter

Units: MV (mV), V, or KV (kV) (V applies when this parameter is omitted.)

Settings are reset to default when the \*RST command is sent. (MINimum)

### Response

NR3

### Example

```
VOLT:PROT:LOW 1.5
```

## VOLT:PROT:LOW:STAT

Enables/disables undervoltage protection (UVP).

### Command

```
[ :SOURce ]:VOLTage:PROTection[:LEVel]:LOWer:STATe <boolean>
[ :SOURce ]:VOLTage:PROTection[:LEVel]:LOWer:STATe?
```

### Parameter

Set value:	ON (1)	Enabled
	OFF (0)	Disabled (default)

Settings are reset to default when the \*RST command is sent.

### Response

boolean

### Example

```
VOLT:PROT:LOW:STAT ON
```

## VOLT:PULS:DCYC

Sets the duty cycle of the pulse function in CV mode.  
Settings cannot be performed while a sequence is running.

### Command

```
[ :SOURce ] :VOLTage:PULSe:DCYClE <numeric>
[ :SOURce ] :VOLTage:PULSe:DCYClE?
```

### Parameter

Set value: 2.5 to 97.5 (Resolution:0.01, Default: MINimum)  
Unit: PCT  
Settings are reset to default when the \*RST command is sent.

### Response

NR3

### Example

```
CURR:PULS:DCYC 40
```

## VOLT:PULS:FREQ

Sets the frequency of the pulse function in CV mode.  
Settings cannot be performed while a sequence is running.

### Command

```
[ :SOURce ] :VOLTage:PULSe:FREQuency <numeric>
[ :SOURce ] :VOLTage:PULSe:FREQuency?
```

### Parameter

Set value: 1 Hz to 1000 Hz (Default: MINimum)  
Unit: HZ  
Resolution: Varies depending on the frequency before the setting.  
1 Hz to 10 Hz: 0.01 Hz  
10 Hz to 100 Hz: 0.1 Hz  
100 to 1000 Hz: 1 Hz

Settings are reset to default when the \*RST command is sent.

### Response

NR3

### Example

```
VOLT:PULS:FREQ 50
```

## VOLT:PULS:HIGH

For the pulse function in CV mode, sets the high level current.

Cannot be set for the value less than the set value of VOLT:PULS:LOW. Settings cannot be performed while a sequence is running.

### Command

```
[ :SOURce ] :VOLTage:PULSe:HIGH <numeric>  
[ :SOURce ] :VOLTage:PULSe:HIGH?
```

### Parameter

Units: MV (mV), V, or KV (kV) (V applies when this parameter is omitted.)

Settings are reset to default when the \*RST command is sent. (0 V)

### Response

NR3 [A]

### Example

```
VOLT:PULS:HIGH 13.0
```

## VOLT:PULS:LOW

For the pulse function in CV mode, sets the low level current.

Cannot be set for the value above the set value of VOLT:PULS:HIGH. Settings cannot be performed while a sequence is running.

### Command

```
[ :SOURce ] :VOLTage:PULSe:LOW <numeric>  
[ :SOURce ] :VOLTage:PULSe:LOW?
```

### Parameter

Units: MV (mV), V, or KV (kV) (V applies when this parameter is omitted.)

Settings are reset to default when the \*RST command is sent. (0 V)

### Response

NR3 [A]

### Example

```
VOLT:PULS:LOW 13.0
```

## VOLT:RESP

Sets the response in the CV mode.

Settings cannot be performed while a sequence is running.

### Command

```
[ :SOURce ] :VOLTage:RESPonse[ :SPEEd ] <character>
[ :SOURce ] :VOLTage:RESPonse[ :SPEEd ] ?
```

### Parameter

Set value:	SLOW	Normal
	FAST	High-speed (default)

Settings are reset to default when the \*RST command is sent.

### Response

character

### Example

```
VOLT:RESP FAST
```

## VOLT:SINE:AMPL

Sets the amplitude of the CV mode sine function (peak-to-peak value).

Cannot be set in the following cases:

- While a sequence is running
- When the total of the set value of VOLT:SINE:AMPL ÷ 2 and the set value of VOLT:SINE:OFFS is outside the setting range (0 % to 105 % of the rated voltage).

### Command

```
[ :SOURce ] :VOLTage:SINE:AMPLitude <numeric>
[ :SOURce ] :VOLTage:SINE:AMPLitude ?
```

### Parameter

The minimum value is 0 V and the maximum value is 105 % of the rated voltage. (Default: 0 V)

Units: MV (mV), V, or KV (kV) (V applies when this parameter is omitted.)

Settings are reset to default when the \*RST command is sent.

### Response

NR3

### Example

```
VOLT:SINE:AMPL 20.0
```

## VOLT:SINE:FREQ

Sets the frequency of the sine function in CV mode.  
Settings cannot be performed while a sequence is running.

### Command

```
[ :SOURce ]:VOLTage:SINE:FREQuency <numeric>
[ :SOURce ]:VOLTage:SINE:FREQuency?
```

### Parameter

Set value: 1 Hz to 1000 Hz (Default: MINimum)  
Unit: HZ  
Resolution: Varies depending on the frequency before the setting.  
1 Hz to 10 Hz: 0.2 Hz  
10 Hz to 100 Hz: 2 Hz  
100 to 1000 Hz: 20 Hz

Settings are reset to default when the \*RST command is sent.

### Response

NR3

### Example

```
CURR:SINE:FREQ 50
```

## VOLT:SINE:OFFS

Sets the correction value of the sine function waveform in CV mode.  
Cannot be set in the following cases:

- While a sequence is running
- When the total of the set value of VOLT:SINE:AMPL ÷ 2 and the set value of VOLT:SINE:OFFS is outside the setting range (0 % to 105 % of the rated voltage).

### Command

```
[ :SOURce ]:VOLTage:SINE:OFFSet <numeric>
[ :SOURce ]:VOLTage:SINE:OFFSet?
```

### Parameter

The minimum value is 0 V and the maximum value is 105 % of the rated voltage. (Default:MINimum)  
Units: MV (mV), V, or KV (kV) (V applies when this parameter is omitted.)  
Settings are reset to default when the \*RST command is sent.

### Response

NR3

### Example

```
VOLT:SINE:OFFS 20.0
```

## VOLT:SLEW

Sets the voltage slew rate in the CV mode.  
Settings cannot be performed while a sequence is running.

### Command

```
[ :SOURce ] :VOLTage :SLEW <Numeric>
[ :SOURce ] :VOLTage :SLEW?
```

### Parameter

Model name	Set value [V/ms]
PXB20K-50	0.0125/0.125/1.25/12.5/25 (Default: 12.5)
PXB20K-250	0.0625/0.625/6.25/62.5/125 (Default: 62.5)
PXB20K-500	0.125/1.25/12.5/125/250 (Default: 125)
PXB20K-1000	0.25/2.5/25/250/500 (Default: 250)
PXB20K-1500	0.375/3.75/37.5/375/750 (Default: 375)

Units: MV (mV), V, or KV (kV) (V applies when this parameter is omitted.)

The units given above are for convenience. The units that are actually applied are mV/ms, V/ms, and kV/ms. If a value other than the above is specified, the adjustable value with the smallest margin equal to or less than the specified value is applied.

Settings are reset to default when the \*RST command is sent. (Maximum value)

## NOTE

- In the CV mode, the set slew rate may not be achieved due to the input capacitance of the DUT.
- Setting the slew rate to the maximum value will result in a slew rate of 25 % or more of the rated value. For example, setting 750 A/ms of PXB20K-1500 will actually result in a slew rate of 375 A/ms or more. It can be used when you need the fastest operation, but note the following points.
  - Overshoot will occur more easily due to the faster response time.
  - OCP alarms may occur when the OCP setting is 20 % or less of the rating. It is because the charge current of the internal capacitor is detected during output even if the DUT is not connected.

### Response

NR3 [V/ms]

### Example

```
VOLT:SLEW 1.25
```

# TRIGger Command

Relates to trigger.

## TRIG:ACQ

Sends a software trigger to start measurement.

To start the measurement, set TRIG:ACQ:SOUR ([p. 141](#)) to BUS and send this command after the INIT:ACQ ([p. 67](#)).

### Command

```
:TRIGger:ACQuire[:IMMediate]
```

## TRIG:ACQ:COUN

Sets the number of times measured values are to be recorded.

Settings cannot be configured during measurement.

### Command

```
:TRIGger:ACQuire:COUNT <NRf>  
:TRIGger:ACQuire:COUNT?
```

### Parameter

Set value: 1 to 65536 (Default: MINimum)

Settings are reset to default when the \*RST command is sent.

### Response

```
NR1
```

### Example

```
TRIG:ACQ:COUN 100
```

## TRIG:ACQ:DEL

Set the delay time until the measurement is started after the measurement trigger is applied. The delay time is applied to each trigger application. Settings cannot be configured during measurement.

### Command

```
:TRIGger:ACQuire:DElay <numeric>
:TRIGger:ACQuire:DElay?
```

### Parameter

Set value: 0 s to 100 s (Default:0 s)

Units: MS (milliseconds), S (seconds), MIN (minutes), HR (hours) (S applies when omitting)

Settings are reset to default when the \*RST command is sent.

### Response

NR3 [S]

### Example

```
TRIG:ACQ:DEL 1.2
```

## TRIG:ACQ:INT:STAT

Sets whether to measure at intervals when the trigger count is 2 or higher.

Sets the trigger count at TRIG:ACQ:COUN ([p. 138](#)). Set the interval using TRIG:ACQ:INT:TIME ([p. 140](#)). Settings cannot be configured during measurement.

### Command

```
:TRIGger:ACQuire:INTerval:STATe <boolean>
:TRIGger:ACQuire:INTerval:STATe?
```

### Parameter

Set value:      ON(1)              Intervals are inserted between measurements.

                 OFF(0)              Intervals are not inserted between measurements. (default)

Settings are reset to default when the \*RST command is sent.

### Response

boolean

### Example

```
TRIG:ACQ:INT:STAT ON
```

## TRIG:ACQ:INT:TIME

Sets the measurement interval time when TRIG:ACQ:INT:STAT is set to ON.  
Set a time longer than SENS:APER ([p. 106](#)). Settings cannot be configured during measurement.

### Command

```
:TRIGger:ACQuire:INTerval:TIME <numeric>
:TRIGger:ACQuire:INTerval:TIME?
```

### Parameter

Set value: 0.0001 s to 3600.0 s (Default: 0.1 s)  
Units: MS (milliseconds), S (seconds), MIN (minutes), HR (hours) (S applies when omitting)  
Settings are reset to default when the \*RST command is sent.

### Response

NR3

### Example

```
TRIG:ACQ:INT:TIME 3
```

## TRIG:ACQ:MSYN

Sends a measurement sync signal.  
If you enter this command to any of the PXB series connected in synchronization, measurement starts in the PXB series in synchronization simultaneously.  
In response to PXB series you wish to synchronize, TRIG:ACQ:SOUR ([p. 141](#)) needs to be set to MSYNc.

### Command

```
TRIGger:ACQuire:MSYNc[:IMMediate]
```

## TRIG:ACQ:SOUR

Clears the measurement trigger wait state and sets the trigger source for starting measurements. Settings cannot be configured during measurement.

### Command

```
:TRIGger:ACQuire:SOURce <character>
:TRIGger:ACQuire:SOURce?
```

### Parameter

Set value:	IMMEDIATE	Measurement is started at the internal timing of PXB series without waiting for trigger application. (default)
	BUS	The trigger is applied when *TRG or TRIG:ACQ ( <a href="#">p. 138</a> ) is received.
	EXTERNAL	The trigger is applied when a measurement trigger signal is input to the EXT CONT connector.
	MSYNc	The step is executed when TRIG:ACQ:MSYN ( <a href="#">p. 140</a> ) is received.
	OSOFF	Measurement is started at the timing that the output is turned off.

Settings are reset to default when the \*RST command is sent.

### Response

character

### Example

```
TRIG:ACQ:SOUR BUS
```

## TRIG:TRAN

Sends a software trigger of sequence.

Setting TRIG:TRAN:SOUR ([p. 143](#)) to BUS and sending this command after INIT:TRAN:PROG ([p. 67](#)) will start the sequence.

### Command

```
:TRIGger:TRANsient[:IMMEDIATE]
```

## TRIG:TRAN:EXEC?

Queries the execution state of sequence function.

Returns the program execution state, the name of the program being executed, the step number being executed, and the number of loops being executed.

### Command

```
:TRIGger:TRANsient:EXECution[:STATe]?
```

### Response

Returns <IDLE|WTG|RUN|PAUS>, <name\_string>, <step\_NR1>, and <loop\_NR1>.

IDLE: Sequence is stopped

WTG: Trigger wait

RUN: Being executed

PAUS: Paused

<name\_string>: Name of the program being executed (returns "" when the program is not running)

<step\_NR1>: Step number being executed (0 is returned when the program is not running)

<loop\_NR1>: Number of loops being executed (0 is returned when the program is not running)

### Response example

When the program is not running

```
IDLE, "", +0, +0
```

When in a trigger wait state right after INIT

```
WTG, "Program1", +1, +1
```

When the 5th loop of the program is running

```
RUN, "Program1", +1, +5
```

## TRIG:TRAN:MSYN

Sends a sequence sync signal.s

If synchronized PXB series are in a sequence start trigger wait state or step start trigger wait state, entering this command to any of the PXB series starts the sequence or step simultaneously.

In response to PXB series you wish to synchronize, the trigger source (TRIG:TRAN:SOUR (p.143) or PROG:STEP<n>:TRIG:WAIT (p.105)) needs to be set to MSYNc.

### Command

```
:TRIGger:TRANsient:MSYNc[:IMMediate]
```

## TRIG:TRAN:PAUS

Pauses a sequence being executed.

This function forcibly stops the execution time (PROG:STEP<n>:DWEL (p.98)) of the program step being executed at present.

### Command

```
:TRIGger:TRANsient:PAUSE
```

## TRIG:TRAN:RES

Resumes the paused sequence from the point at which it was paused.

### Command

```
:TRIGger:TRANsient:RESume
```

## TRIG:TRAN:SOUR

Sets the conditions for starting the sequence by releasing the trigger wait of the sequence (trigger source) for the program selected in PROG:NAME.

### NOTE

Regardless of whether the program is registered in the chain or not, if the program settings are changed, the chain will be unlocked.

### Command

```
:TRIGger:TRANsient:SOURce <character>
:TRIGger:TRANsient:SOURce?
```

### Parameter

You can select one from the available choices below.

Set value:	IMMEDIATE	The sequence is started when RUN on the front panel of the PXB series is pressed, or when the INIT:TRAN:PROG ( <a href="#">p. 67</a> ) is received. (default)
	BUS	The sequence is started when receiving the software trigger (*TRG).
	EXTernal	The trigger is applied at the timing that a trigger signal is input to the EXT CONT connector.
	MSYNc	The sequence is started when the MSync key on the front panel of the PXB series connected in synchronization is pressed. Or, the sequence is started when TRIG:TRAN:MSYN ( <a href="#">p. 142</a> ) is received.

Settings are reset to default when the \*RST command is sent.

### Response

character

### Example

```
TRIG:TRAN:SOUR BUS
```

# SYSTem Command

Relates to system settings.

## SYST:BEEP

Sets the buzzer sound ON/OFF in a batch when operation is invalid, when a protection function is activated, or when an SCPI error occurs.

### Command

```
:SYSTem:BEEPer[:ALL][:STATe] <boolean>  
:SYSTem:BEEPer[:ALL][:STATe]?
```

### Parameter

Set value:	ON(1)	ON (Default)
	OFF(0)	OFF

The setting may change when a SYST:BEEP:KEY, SYST:BEEP:PROT, or SYST:BEEP:SCPI is sent.

### Response

```
<boolean>,<boolean>,<boolean>
```

Returns in a comma-separated format when operation is invalid, when a protection function is activated, or when an SCPI error occurs.

### Example

```
SYST:BEEP OFF
```

## SYST:BEEP:KEY

Sets the buzzer sound ON/OFF in case of invalid operation.

### Command

```
:SYSTem:BEEPer:KEY[:STATe] <boolean>  
:SYSTem:BEEPer:KEY[:STATe]?
```

### Parameter

Set value:	ON(1)	ON (Default)
	OFF(0)	OFF

The setting may change when a SYST:BEEP is sent.

### Response

```
boolean
```

### Example

```
SYST:BEEP:KEY OFF
```

## SYST:BEEP:PROT

Turns ON/OFF the buzzer that sounds when a protection function is activated.

### Command

```
:SYSTem:BEEPer:PROTection[:STATe] <boolean>
:SYSTem:BEEPer:PROTection[:STATe]?
```

### Parameter

Set value:	ON(1)	ON (Default)
	OFF(0)	OFF

The setting may change when a SYST:BEEP is sent.

### Response

boolean

### Example

```
SYST:BEEP:PROT OFF
```

## SYST:BEEP:SCPI

Turns ON/OFF the buzzer that sounds when an SCPI error occurs.

### Command

```
:SYSTem:BEEPer:SCPI[:STATe] <boolean>
:SYSTem:BEEPer:SCPI[:STATe]?
```

### Parameter

Set value:	ON(1)	ON (Default)
	OFF(0)	OFF

The setting may change when a SYST:BEEP is sent.

### Response

boolean

### Example

```
SYST:BEEP:SCPI OFF
```

## SYST:COMM:RLST



Enables/disables the panel operation and remote operation of PXB series.

### Command

```
:SYSTem:COMMunicate:RLSTate <character>
:SYSTem:COMMunicate:RLSTate?
```

### Parameter

In the table below, the operations with the checks in the corresponding cells are enabled depending on the settings.

Set value	Panel operation	Remote operation	Notes
LOCal	✓	✓	Default This is a substitute command for IEEE488.1 ren FALSE (Remote Disable).
REMote	–	✓	The Remote icon (  ) appears in the top right of the display. Pressing and holding the Remote icon will change the state to LOCAL. This is a substitute command for IEEE 488.1 ren (Remote Enable). This is also the substitute command for address specification.
RWLock	–	✓	The RWLS icon (  ) appears in the top right of the display. Pressing and holding the icon does not change the state to LOCAL. This is a substitute command for IEEE 488.1 llo (Local Lock Out).

To reset the settings to the factory default, turn off PXB series and then back on.

### Response

character

### Example

```
SYST:COMM:RLST REM
```

## SYST:DATE

Sets the date for the clock.  
Time can be set in SYST:TIME ([p. 152](#)).

### Command

```
:SYSTem:DATE <year_NR1>,<month_NR1>,<day_NR1>
:SYSTem:DATE?
```

### Parameter <year\_NR1>

Set value: 2022 to 2037 (year)

### Parameter <month\_NR1>

Set value: 1 to 12 (month)

### Parameter <day\_NR1>

Set value: 1 to 31 (day)

### Response

Returns in the order of the year, month, and day in a comma-separated NR1 format.

### Example

```
SYST:DATE 2022,8,30
```

## SYST:ERR?

Reads the oldest error information or event information from the error queue.  
Errors that have been read are cleared. The error queue can hold up to 16 errors.

### Command

```
:SYSTem:ERRor[:NEXT]?
```

### Response

NR1, String

Returns in the order of error number, error name in a comma-separated format.

### Response example

Returns the oldest error or event from the error/event queue in the following format, in response to SYST:ERR?.

Example: If there is no error or event

```
0, "No error"
```

Example: If a command that cannot be executed in the present operating status is received

```
-221, "Settings conflict"
```

Example: If the error queue contains at least 17 pieces of error information

```
-350, "Queue overflow"
```

For details on errors, see the Command error reference ([p. 185](#)).

## SYST:ERR:COUN?

Queries the number of unread errors in the error queue.

### Command

```
:SYSTem:ERRor:COUNT?
```

### Response

```
NR1
```

## SYST:KLOC

Enables/disables panel control lock.

### Command

```
:SYSTem:KLOCK[:STATe] <boolean>  
:SYSTem:KLOCK[:STATe]?
```

### Parameter

Set value:	ON (1)	The panel control is locked.
	OFF (0)	The panel control lock is released. (default)

### Response

```
boolean
```

### Example

```
SYST:KLOC ON
```

## SYST:KLOC:LEV

Sets the panel control lock level.

To enable/disable the lock, use the SYST:KLOC (p.148).

### Command

```
:SYSTem:KLOCk:LEVel <NRf>
:SYSTem:KLOCk:LEVel?
```

### Parameter

Set value:	1	Allowed function
		<ul style="list-style-type: none"> <li>• OUTPUT on/off</li> <li>• Recall preset memory</li> <li>• Release key lock</li> </ul>
	2	Allowed function
		<ul style="list-style-type: none"> <li>• OUTPUT on/off</li> <li>• Release key lock</li> </ul>
	3	Allowed function
		<ul style="list-style-type: none"> <li>• OUTPUT off</li> <li>• Release key lock</li> </ul>

### Response

NRf

### Example

```
SYST:KLOC:LEV 3
```

## SYST:MSYN?

Queries whether synchronization connection is enabled or disabled.

A connection in synchronization is recognized as active when the power supply of the PXB series connected to the EXT SYNC connector is turned on.

### Command

```
:SYSTem:MSYNc[:STATe]?
```

### Response

boolean

## SYST:PARA:UNIT:COUN?

Queries the number of parallel operation units including the master unit.

### Command

```
:SYSTem:PARAllel:UNIT:COUNT?
```

### Response

NR1

1 is returned for standalone operation.

## SYST:PON

Sets the panel setting state when the POWER switch is turned on.

For the output state from the DC OUTPUT terminal, set in OUTP:PON ([p.83](#)).

### Command

```
:SYSTem:PON[:STATe] <character>
```

```
:SYSTem:PON[:STATe]?
```

### Parameter

Set value:	RST	Start in *RST command transmission state (default)
	RCL	Starts according to the contents of the setup memory specified by SYST:PON:REC.
	AUTO	Start with the same settings as when the power supply was turned off the previous time.

### Response

character

### Example

```
SYST:PON AUTO
```

## SYST:PON:REC

Specifies the number of setup memory to apply when SYST:PON is set to RCL.

### Command

```
:SYSTem:PON:RECall <numeric>
```

```
:SYSTem:PON:RECall?
```

### Parameter

Set value: 1 to 20 (Default: 1)

### Response

NR1

### Example

```
SYST:PON:REC 2
```

## SYST:PROT:LINE:VOLT

Sets the voltage of line overvoltage protection (LOVP).

When a voltage at the set value or higher is applied to the AC INPUT terminal, an alarm occurs, and the output gets turned off.

### Command

```
:SYSTem:PROTection:LINE:VOLTage[:UPPer] <Numeric>
:SYSTem:PROTection:LINE:VOLTage[:UPPer]?
```

### Parameter

Unit: V

Settings are reset to default when the \*RST command is sent.<MAXimum>

### Response

NRf

### Example

```
SYST:PROT:LINE:VOLT 210
```

## SYST:RSEN

Sets remote sensing function on/off.

Settings cannot be configured during output.

### Command

```
:SYSTem:RSEnSsing[:STATe] <boolean>
:SYSTem:RSEnSsing[:STATe]?
```

### Parameter

Set value:	ON (1)	On
	OFF (0)	Off (default)

### Response

boolean

### Example

```
SYST:CONF:RSEN ON
```

## SYST:TIME

Sets the time for the clock.

Date can be set in SYST:DATE ([p. 147](#)).

### Command

```
:SYSTem:TIME <hour_NR1>,<min_NR1>,<sec_NR1>
:SYSTem:TIME?
```

### Parameter <hour\_NR1>

Set value: 0 to 23 (hour)

### Parameter <min\_NR1>

Set value: 0 to 59 (minute)

### Parameter <sec\_NR1>

Set value: 0 to 59 (second)

### Response

Returns in the order of the hour, minute, and second in NR1 format.

### Example

```
SYST:TIME 13,0,0
```

## SYST:TIME:ADJ

Automatically synchronizes the system clock using the NTP server on the network.

### Command

```
:SYSTem:TIME:ADJust
```

## SYST:TZON

Sets the time zone of the system clock.

Use SYST:TZON:CAT? to check the time zone ID.

### Command

```
:SYSTem:TZONe "<string>"
:SYSTem:TZONe?
```

### Parameter

Set value: Time zone ID or UTC (The default value is "UTC")

### Response

string

### Example

```
SYST:TZON "Asia/Tokyo"
```

## SYST:TZON:CAT?

Queries the time zone IDs that can be used.

### Command

```
:SYSTem:TZONe:CATalog? <character>
```

### Parameter

Select the region to query.

TZONe1: UTC and Africa, America Region ("UTC", "Africa", and "America")

TZONe2: UTC and Africa, regions outside the America ("Antarctica", "Arctic", "Asia", "Atlantic", "Australia", "Europe", "Indian", and "Pacific")

An error is returned when no region is selected.

### Response

"string"

Returns multiple time zone ID character strings in a comma-separated format.

### Response example

Returns the following as a response to SYST:TZON:CAT? TZON1.

```
"UTC", "Africa/Abidjan", "Africa/Accra", "Africa/Addis_Ababa", ... (omitted)
```

## SYST:VERS?

Queries the version of the SCPI specifications that this product complies with.

### Command

```
:SYSTem:VERSion?
```

### Response

Returns 1999.0.

# STATUS Command

Relates to PXB series operating status.

## Status Report Structure

### Normal operation (using a single channel)

A "+" represents the logical OR of the register bits.

1999 SCPI Syntax & Style

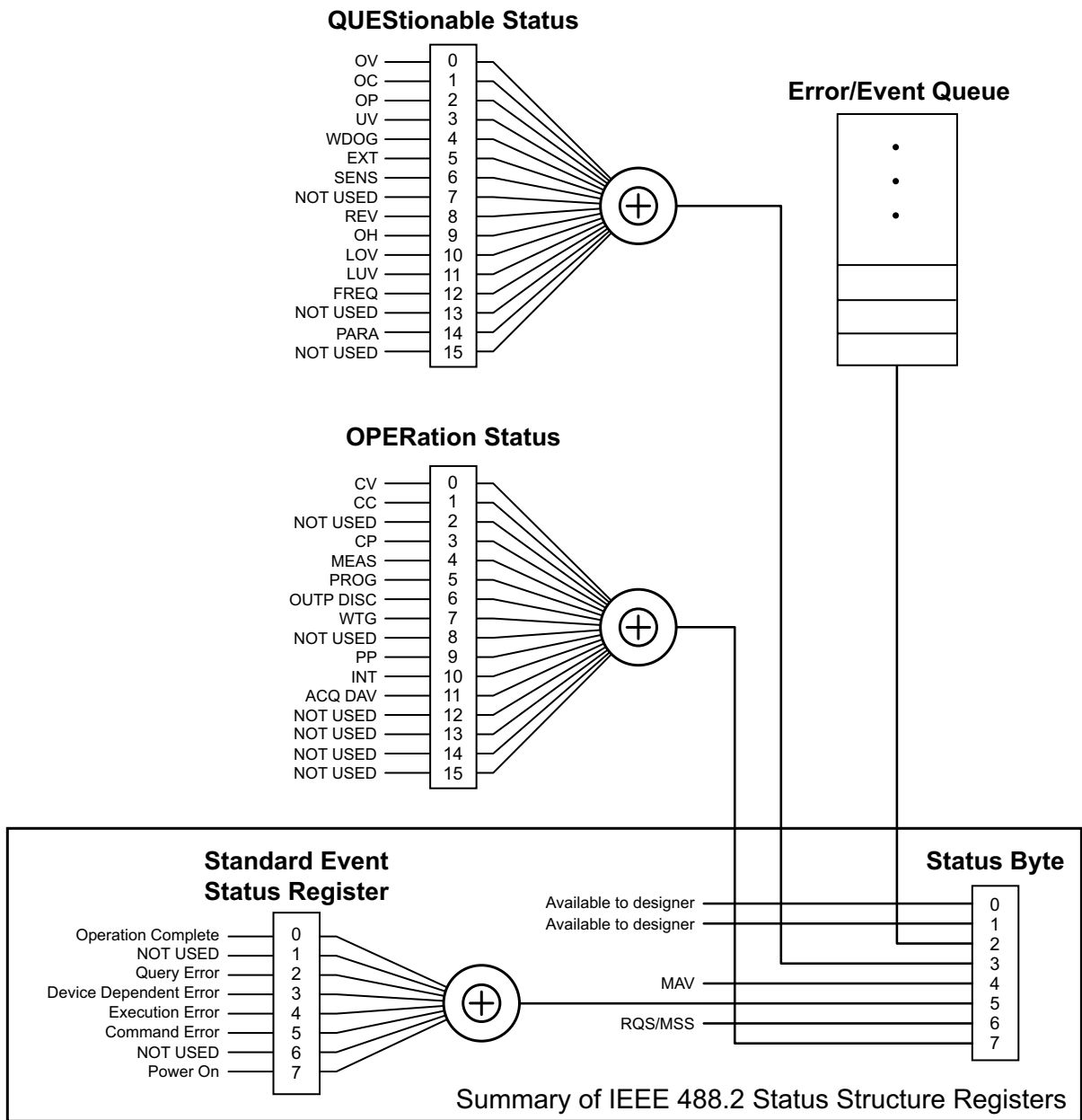

## When multichannel is in use

A “+” represents the logical OR of the register bits. The OPERation Status, OPERation:INSTrument Status, and OPERation:INSTrument:ISUMmary Status registers all operate the same way.

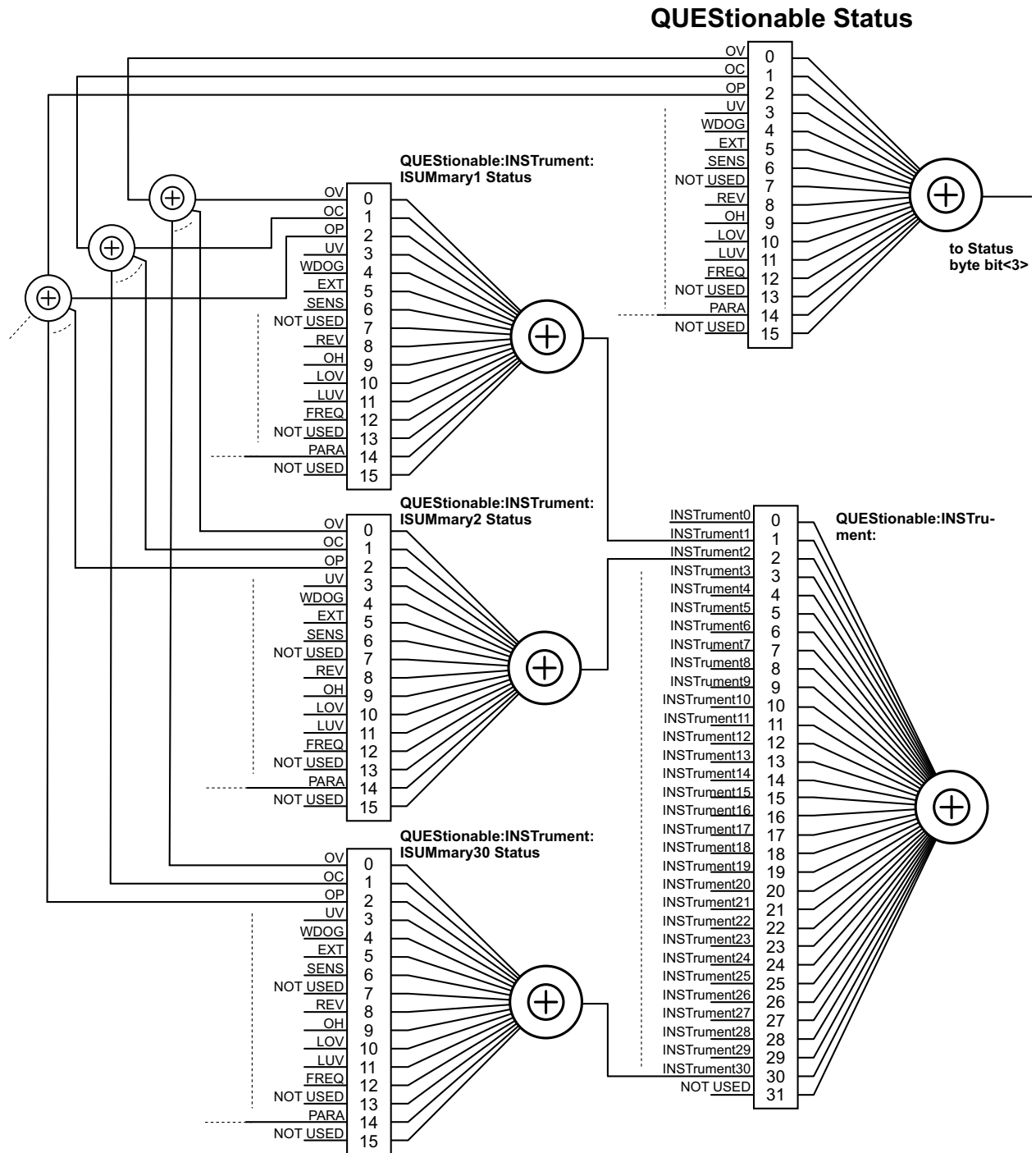

# Standard Architecture

IEEE 488.2 and SCPI registers are used for status reports.

In each SCPI status register, there are the following sub registers: the CONDition register, the EVENT register, the ENABle register, the PTRansition filter, and the NTRansition filter.

## CONDition register

Transitions of the CONDition register are automatic and reflect the condition of this product in real time. Reading this register does not affect its contents.

## EVENT register

The EVENT register bits are automatically set according to the changes in the CONDition register. The rule for setting the bits varies depending on the positive and negative transition registers (PTRansition and NTRansition). The EVENT register is reset when it is read.

## ENABle register

The ENABle register enables reports to the summary bit or status bit of the event bits.

## Transition filters

Use the PTRansition (positive transition) filter to report events when the condition changes from false to true.

Use the NTRansition (negative transition) filter to report events when the condition changes from true to false.

If both the positive filter and negative filter are set to true, events can be reported each time the status changes. If both filters are cleared, event reporting is disabled.

## Status Byte Register

The status byte register can be read by using the IEEE 488.2 common command “\*STB?”

\*STB? makes the device transmit the contents of the status byte register and the master status summary (MSS) message. \*STB? does not change the status byte, MSS, and RQS.

Bit	Bit weight	Bit name	Description
0	1	Reserved	Reserved for future use by IEEE 488. The bit value is notified as zero.
1	2	Reserved	
2	4	Error/Event Queue	If data exists in the error or event queue, this bit is set to true.
3	8	Questionable Status Register (QUES)	This bit is set to true when a bit is set in the QUESTIONable event status register and the corresponding bit in the QUESTIONable status enable register is true.
4	16	Message Available (MAV)	This bit is set to true when a request is received from the digital programming interface and this product is ready to generate the data byte.
5	32	Standard Event Status Bit Summary (ESB)	This bit is set to true when a bit is set in the event status register.
6	64	Request Service (RQS)	This bit is set to true when a bit is set in the service request enable register and the corresponding bit exists in the status byte.
		Master Status Summary (MSS)	This bit is set when any bit in the status byte register is set to 1, and the corresponding bit in the service request enable register is set to 1.
7	128	Operation Status Register (OPER)	This bit is set to true when a bit is set in the OPERATION event status register and the corresponding bit in the OPERATION status enable register is set.
8 to 15	-	-	Not used

# Event Status Register

The event status register bits are set when certain events occur during product operation. All the event status register bits are set by the error event queue.

This register is defined by the IEEE 488.2 standard and is controlled using the IEEE 488.2 common commands \*ESE, \*ESE?, and \*ESR?.

You can check the error content with SYST:ERR?.

Bit	Bit weight	Bit name	Description	Error number
0	1	Operation Complete (OPC)	Set when an *OPC command is received and all operations in standby have been completed.	-800 to -899
1	2	Request Control (RQC)	Not used	-
2	4	Query Error (QYE)	Set when an attempt is made to read data from the output queue when there is no data or when the output queue is not in the wait state. This indicates that there is no data in the output queue.	-400 to -499
3	8	Device Dependent Error (DDE)	Set when there is a device-specific error.	-300 to -399 100 to 999
4	16	Execution Error (EXE)	Set when this product evaluates that the program data after the header is outside the formal input range or does not match the specifications of this product. This indicates that a valid SCPI command may not be executed correctly depending on the state of this product.	-200 to 299
5	32	Command Error (CME)	Set when an IEEE 488.2 syntax error is detected by the parser, when an unidentifiable header is received, or when a group execution trigger enters the internal IEEE 488.2 SCPI command input buffer.	-100 to -199
6	64	User Request (URQ)	Not used	-
7	128	Power On (PON)	Set when the power is turned on.	-
8 to 15	-	-	Not used	-

## OPERation Status Register

The OPERation status register is a 16-bit register that contains information about the normal operating status of this product.

Bit	Bit weight	Bit name	Description
0	1	CV	Operation in progress in the CV mode.
1	2	CC	Operation in progress in the CC mode.
2	4	-	Not used
3	8	CP	Operation in progress in the CP mode.
4	16	MEAS	Measurement in progress.
5	32	PROG	The sequence is running.
6	64	OUTP DISC	DC OUTPUT terminal is discharging.
7	128	WTG	Trigger wait state.
8	256	-	Not used
9	512	PP	The program is paused.
10	1024	INT	Integrating
11	2048	ACQ DAV	Data to be acquired is valid (acquirable).
12	4096	-	Not used
13	8192	-	Not used
14	16384	-	Not used
15	32768	-	Not used

### STAT:OPER?

Queries the event of the OPERation status register.  
A query clears the contents of the register.

#### Command

```
:STATus:OPERation[:EVENT]?
```

#### Response

```
NR1
```

### STAT:OPER:COND?

Queries the condition of the OPERation status register.

#### Command

```
:STATus:OPERation:CONDition?
```

#### Response

```
NR1
```

## STAT:OPER:ENAB

Sets the enable register of the OPERATION status register.

### Command

```
:STATus:OPERation:ENABle <NRf>  
:STATus:OPERation:ENABle?
```

### Parameter

Set value: 0 to 65535

### Response

NR1

## STAT:OPER:NTR

Sets the negative transition filter of the OPERATION status register.

### Command

```
:STATus:OPERation:NTRansition <NRf>  
:STATus:OPERation:NTRansition?
```

### Parameter

Set value: 0 to 65535

### Response

NR1

## STAT:OPER:PTR

Sets the positive transition filter of the OPERATION status register.

### Command

```
:STATus:OPERation:PTRansition <NRf>  
:STATus:OPERation:PTRansition?
```

### Parameter

Set value: 0 to 65535

### Response

NR1

## OPERation:INSTrument Sub Register

This is the subregister (32 bits) of bit 13 of the OPERation status register.

Bit	Bit weight	Bit name	Description
0	1	INSTrument0	Summary bit of channel 0 (OPER:INST:ISUM0)
1	2	INSTrument1	Summary bit of channel 1 (OPER:INST:ISUM1)
2	4	INSTrument2	Summary bit of channel 2 (OPER:INST:ISUM2)
3	8	INSTrument3	Summary bit of channel 3 (OPER:INST:ISUM3)
4	16	INSTrument4	Summary bit of channel 4 (OPER:INST:ISUM4)
5	32	INSTrument5	Summary bit of channel 5 (OPER:INST:ISUM5)
6	64	INSTrument6	Summary bit of channel 6 (OPER:INST:ISUM6)
7	128	INSTrument7	Summary bit of channel 7 (OPER:INST:ISUM7)
8	256	INSTrument8	Reserved
9	512	INSTrument9	Reserved
10	1024	INSTrument10	Reserved
11	2048	INSTrument11	Reserved
12	4096	INSTrument12	Reserved
13	8192	INSTrument13	Reserved
14	16384	INSTrument14	Reserved
15	32768	INSTrument15	Not used

### STAT:OPER:INST?

Queries the event of the OPERation:INSTrument subregister.

#### Command

```
:STATus:OPERation:INSTrument[:EVENT]?
```

#### Response

NR1

### STAT:OPER:INST:COND?

Queries the condition of the OPERation:INSTrument subregister.

#### Command

```
:STATus:OPERation:INSTrument:CONDition?
```

#### Response

NR1

## STAT:OPER:INST:ENAB

Sets the enable register of the OPERATION:INSTrument subregister.

### Command

```
:STATus:OPERation:INSTrument:ENABle <NRf>  
:STATus:OPERation:INSTrument:ENABle?
```

### Parameter

Set value: 0 to 32768

### Response

NR1

## STAT:OPER:INST:NTR

Sets the negative transition filter of the OPERATION:INSTrument subregister.

### Command

```
:STATus:OPERation:INSTrument:NTRansition <NRf>  
:STATus:OPERation:INSTrument:NTRansition?
```

### Parameter

Set value: 0 to 32768

### Response

NR1

## STAT:OPER:INST:PTR

Sets the positive transition filter of the OPERATION:INSTrument subregister.

### Command

```
:STATus:OPERation:INSTrument:PTRansition <NRf>  
:STATus:OPERation:INSTrument:PTRansition?
```

### Parameter

Set value: 0 to 32768

### Response

NR1

## OPERation:INSTrument:ISUMmary<n> Sub Register

This is the subregister of bit <n> of the OPERation:INSTrument subregister. This is a 16-bit register that contains the information about the normal operating status of PXB series whose channel you specified.

Use <n> to specify the channel number. For example, channel 2 is specified as "OPER:INST:ISUM2."

Bit	Bit weight	Bit name	Description
0	1	CV	Operation in progress in the CV mode.
1	2	CC	Operation in progress in the CC mode.
2	4	-	Not used
3	8	CP	Operation in progress in the CP mode.
4	16	MEAS	Measurement in progress.
5	32	PROG	The sequence is running.
6	64	OUTP DISC	DC OUTPUT terminal is discharging.
7	128	WTG	Trigger wait state.
8	256	-	Not used
9	512	PP	The program is paused.
10	1024	INT	Integrating
11	2048	ACQ DAV	Data to be acquired is valid (acquirable).
12	4096	-	Not used
13	8192	-	Not used
14	16384	-	Not used
15	32768	-	Not used

### STAT:OPER:INST:ISUM<n>?

Queries the event of the OPERation:INSTrument:ISUMmary<n> subregister.

Use <n> to specify the channel number. For example, to specify channel 2 STAT:OPER:INST:ISUM<n>?, the command shall be STAT:OPER:INST:ISUM2?.

#### Command

```
:STATus:OPERation:INSTrument:ISUMmary<n>[:EVENT]?
```

#### Response

```
NR1
```

## STAT:OPER:INST:ISUM<n>:COND?

Queries the condition of the OPERATION:INSTRUMENT:ISUMmary<n> subregister.

Use <n> to specify the channel number. For example, to specify channel 2 STAT:OPER:INST:ISUM<n>:COND?, the command shall be STAT:OPER:INST:ISUM2:COND?.

### Command

```
:STATus:OPERation:INSTRument:ISUMmary<n>:CONDition?
```

### Response

```
NR1
```

## STAT:OPER:INST:ISUM<n>:ENAB

Sets the enable register of the OPERATION:INSTRUMENT:ISUMmary<n> subregister.

Use <n> to specify the channel number. For example, to specify channel 2 STAT:OPER:INST:ISUM<n>:ENAB, the command shall be STAT:OPER:INST:ISUM2:ENAB.

### Command

```
:STATus:OPERation:INSTRument:ISUMmary<n>:ENABle <NRf>
:STATus:OPERation:INSTRument:ISUMmary<n>:ENABle?
```

### Parameter

Set value: 0 to 65535

### Response

```
NR1
```

## STAT:OPER:INST:ISUM<n>:NTR

Sets the negative transition filter of the OPERATION:INSTRUMENT:ISUMmary<n> subregister.

Use <n> to specify the channel number. For example, to specify channel 2 STAT:OPER:INST:ISUM<n>:NTR, the command shall be STAT:OPER:INST:ISUM2:NTR.

### Command

```
:STATus:OPERation:INSTRument:ISUMmary<n>:NTRansition <NRf>
:STATus:OPERation:INSTRument:ISUMmary<n>:NTRansition?
```

### Parameter

Set value: 0 to 65535

### Response

```
NR1
```

## STAT:OPER:INST:ISUM<n>:PTR

Sets the positive transition filter of the OPERation:INSTrument subregister.

Use <n> to specify the channel number. For example, to specify channel 2 STAT:OPER:INST:ISUM<n>:PTR, the command shall be STAT:OPER:INST:ISUM2:PTR.

### Command

```
:STATus:OPERation:INSTrument:ISUMmary<n>:PTRansition <NRf>  
:STATus:OPERation:INSTrument:ISUMmary<n>:PTRansition?
```

### Parameter

Set value: 0 to 65535

### Response

NR1

## QUEStionable Status Register

The QUEStionable status register is a 16-bit register that stores information related to the following product's status and events. The QUEStionable status register bits may indicate that there are problems with the product's measured data.

Bit	Bit weight	Bit name	Description
0	1	OV	Overvoltage protection has been activated.
1	2	OC	Overcurrent protection has been activated.
2	4	OP	Overpower protection has been activated.
3	8	UV	Undervoltage protection has been activated.
4	16	WDOG	Communication error protection has been activated.
5	32	EXT	An alarm signal was input to the EXT CONT connector.
6	64	SENS	The voltage difference between DC OUTPUT terminal and the sensing terminal is 10 % or more of the rated output voltage.
7	128	-	Not used
8	256	REV	A negative voltage was applied to the DC OUTPUT terminal.
9	512	OH	The temperature of the internal devices exceeds the standard.
10	1024	LOV	A voltage at or higher the LINE OVP set value was applied to the AC INPUT terminal.
11	2048	LUV	200 Vac models: Input voltage at the AC INPUT terminal is less than 175 V. 400 Vac models: Input voltage at the AC INPUT terminal is less than 333 V.
12	4096	FREQ	A frequency other than the input frequency (42 Hz to 68 Hz) was entered to the INPUT terminal.
13	8192	-	Not used
14	16384	PARA	An alarm that occurs only during parallel operation has been activated.
15	32768	-	Not used

### STAT:QUES?

Queries the event of the QUEStionable status register.  
A query clears the contents of the register.

#### Command

```
:STATus:QUEStionable[:EVENT]?
```

#### Response

```
NR1
```

### STAT:QUES:COND?

Queries the condition of the QUEStionable status register.

#### Command

```
:STATus:QUEStionable:CONDition?
```

#### Response

```
NR1
```

## STAT:QUES:ENAB

Sets the enable register of the QUEStionable status register.

### Command

```
:STATus:QUEStionable:ENABle <NRf>  
:STATus:QUEStionable:ENABle?
```

### Parameter

Set value: 0 to 65535

### Response

NR1

## STAT:QUES:NTR

Sets the negative transition filter of the QUEStionable status register.

### Command

```
:STATus:QUEStionable:NTRansition <NRf>  
:STATus:QUEStionable:NTRansition?
```

### Parameter

Set value: 0 to 65535

### Response

NR1

## STAT:QUES:PTR

Sets the positive transition filter of the QUEStionable status register.

### Command

```
:STATus:QUEStionable:PTRansition <NRf>  
:STATus:QUEStionable:PTRansition?
```

### Parameter

Set value: 0 to 65535

### Response

NR1

## QUEStionable:INSTRument Sub Register

This is the subregister (32 bits) of bit 13 of the QUEStionable status register.

Bit	Bit weight	Bit name	Description
0	1	INSTRument0	Summary bit of channel 0 (QUES:INST:ISUM0)
1	2	INSTRument1	Summary bit of channel 1 (QUES:INST:ISUM1)
2	4	INSTRument2	Summary bit of channel 2 (QUES:INST:ISUM2)
3	8	INSTRument3	Summary bit of channel 3 (QUES:INST:ISUM3)
4	16	INSTRument4	Summary bit of channel 4 (QUES:INST:ISUM4)
5	32	INSTRument5	Summary bit of channel 5 (QUES:INST:ISUM5)
6	64	INSTRument6	Summary bit of channel 6 (QUES:INST:ISUM6)
7	128	INSTRument7	Summary bit of channel 7 (QUES:INST:ISUM7)
8	256	INSTRument8	Reserved
9	512	INSTRument9	Reserved
10	1024	INSTRument10	Reserved
11	2048	INSTRument11	Reserved
12	4096	INSTRument12	Reserved
13	8192	INSTRument13	Reserved
14	16384	INSTRument14	Reserved
15	32768	INSTRument15	Not used

### STAT:QUES:INST?

Queries the event of the QUEStionable:INSTRument subregister.

#### Command

```
:STATus:QUEStionable:INSTRument[:EVENT]?
```

#### Response

NR1

### STAT:QUES:INST:COND?

Queries the condition of the QUEStionable:INSTRument subregister.

#### Command

```
:STATus:QUEStionable:INSTRument:CONDition?
```

#### Response

NR1

## STAT:QUES:INST:ENAB

Sets the enable register of the QUESTIONable:INSTrument subregister.

### Command

```
:STATus:QUEStionable:INSTrument:ENABle <NRf>
:STATus:QUEStionable:INSTrument:ENABle?
```

### Parameter

Set value: 0 to 32768

### Response

NR1

## STAT:QUES:INST:NTR

Sets the negative transition filter of the QUESTIONable:INSTrument subregister.

### Command

```
:STATus:QUEStionable:INSTrument:NTRansition <NRf>
:STATus:QUEStionable:INSTrument:NTRansition?
```

### Parameter

Set value: 0 to 32768

### Response

NR1

## STAT:QUES:INST:PTR

Sets the positive transition filter of the QUESTIONable:INSTrument subregister.

### Command

```
:STATus:QUEStionable:INSTrument:PTRansition <NRf>
:STATus:QUEStionable:INSTrument:PTRansition?
```

### Parameter

Set value: 0 to 32768

### Response

NR1

# QUEStionable:INSTrument:ISUMmary<n> Sub Register

This is the subregister of bit <n> of the QUEStionable:INSTrument subregister. This is a 16-bit register that contains the information related to the status of and questionable events that occur during the operation of PXB series whose channel you specified.

Use <n> to specify the channel number. For example, channel 2 is specified as “QUES:INST:ISUM2.”

The QUEStionable status register bits may indicate that there are problems with the measured data.

Bit	Bit weight	Bit name	Description
0	1	OV	Overvoltage protection has been activated.
1	2	OC	Overcurrent protection has been activated.
2	4	OP	Overpower protection has been activated.
3	8	UV	Undervoltage protection has been activated.
4	16	WDOG	Communication error protection has been activated.
5	32	EXT	An alarm signal was input to the EXT CONT connector.
6	64	SENS	The voltage difference between DC OUTPUT terminal and the sensing terminal is 10 % or more of the rated output voltage.
7	128	-	Not used
8	256	REV	A negative voltage was applied to the DC OUTPUT terminal.
9	512	OH	The temperature of the internal devices exceeds the standard.
10	1024	LOV	A voltage at or higher the LINE OVP set value was applied to the AC INPUT terminal.
11	2048	LUV	200 Vac models: Input voltage at the AC INPUT terminal is less than 175 V. 400 Vac models: Input voltage at the AC INPUT terminal is less than 333 V.
12	4096	FREQ	A frequency other than the input frequency (42 Hz to 68 Hz) was entered to the INPUT terminal.
13	8192	-	Not used
14	16384	PARA	An alarm that occurs only during parallel operation has been activated.
15	32768	-	Not used

## STAT:QUES:INST:ISUM<n>?

Queries the event of the QUEStionable:INSTrument:ISUMmary<n> subregister.

Use <n> to specify the channel number. For example, to specify channel 2 STAT:QUES:INST:ISUM<n>?, the command shall be STAT:QUES:INST:ISUM2?.

### Command

```
:STATus:QUEStionable:INSTrument:ISUMmary<n>[:EVENT]?
```

### Response

```
NR1
```

## STAT:QUES:INST:ISUM<n>:COND?

Queries the condition of the QUESTIONable:INSTrument:ISUMmary<n> subregister.

Use <n> to specify the channel number. For example, to specify channel 2 STAT:QUES:INST:ISUM<n>:COND?, the command shall be STAT:QUES:INST:ISUM2:COND?.

### Command

```
:STATus:QUEStionable:INSTrument:ISUMmary<n>:CONDition?
```

### Response

NR1

## STAT:QUES:INST:ISUM<n>:ENAB

Sets the enable register of the QUESTIONable:INSTrument:ISUMmary<n> subregister.

Use <n> to specify the channel number. For example, to specify channel 2 STAT:QUES:INST:ISUM<n>:ENAB, the command shall be STAT:QUES:INST:ISUM2:ENAB.

### Command

```
:STATus:QUEStionable:INSTrument:ISUMmary<n>:ENABle <NRf>
```

```
:STATus:QUEStionable:INSTrument:ISUMmary<n>:ENABle?
```

### Parameter

Set value: 0 to 65535

### Response

NR1

## STAT:QUES:INST:ISUM<n>:NTR

Sets the negative transition filter of the QUESTIONable:INSTrument:ISUMmary<n> subregister.

Use <n> to specify the channel number. For example, to specify channel 2 STAT:QUES:INST:ISUM<n>:NTR, the command shall be STAT:QUES:INST:ISUM2:NTR.

### Command

```
:STATus:QUEStionable:INSTrument:ISUMmary<n>:NTRansition <NRf>
```

```
:STATus:QUEStionable:INSTrument:ISUMmary<n>:NTRansition?
```

### Parameter

Set value:0 to 65535

### Response

NR1

## STAT:QUES:INST:ISUM<n>:PTR

Sets the positive transition filter of the QUESTIONable:INSTRument:ISUMmary<n> subregister.

Use <n> to specify the channel number. For example, to specify channel 2 STAT:QUES:INST:ISUM<n>:PTR, the command shall be STAT:QUES:INST:ISUM2:PTR.

### Command

```
:STATus:QUEStionable:INSTRument:ISUMmary<n>:PTRansition <NRf>
:STATus:QUEStionable:INSTRument:ISUMmary<n>:PTRansition?
```

### Parameter

Set value:0 to 65535

### Response

NR1

## Preset Status

## STAT:PRES

Resets the ENABLE, PTRansition, and NTRansition filter registers of all status registers (including sub registers) to their default values.

### Default settings

STATus:ENABle = 0x0000

STATus:PTRansition = 0x7FFF

STATus:NTRansition = 0x0000

### Command

```
STATus:PRESet
```

# Tutorial

## Basic Configuration

### Outputting

Using the following output conditions as an example, this section explains how to write commands starting from basic configuration up to turning the OUTPUT on.

#### Output condition

Current value on the source side:	30 A
Current value on the sink side:	30 A
Slew rate:	3 A/ms
Current value on the source side of the overcurrent protection:	40 A
Current value on the sink side of the overcurrent protection:	40 A

#### Command examples

```
:FUNction:MODe CC 'Sets the priority operation mode to the CC mode
:CURRent 30 'Sets the current on the source side to 30 A
:CURRent:NEGative 30 'Sets the current on the sink side to 30 A
:CURRent:SLEWrate 3 'Set the slew rate to 3 A/μs
:CURRent:PROTection 40 'Sets the current on the OCP's source side to 40 A
:CURRent:NEGative:PROTection 40 'Sets the current on the OCP's sink side to 40 A
:OUTPut ON 'OUTPUT on
```

### Checking the current's minimum/maximum setting values

The current's minimum/maximum setting values depend on the set current range. You can query the present minimum/maximum setting value by sending a query to which the MINimum or MAXimum parameter is added, as shown below.

```
:CURRent? MINimum
:CURRent? MAXimum
```

# Measuring

This section explains how to take measurements and query the results.

## Taking a measurement and querying the result

In the following command example, a measurement is taken and then the measured value is queried.

```
:MEAS? 'Query the latest measured value after measuring.
```

## Taking several measurements and querying the results

In the following command example, after the output on, INIT:ACQ is entered to immediately take three measurements, and then the measurement is queried.

```
:TRIGger:ACQuire:SOURce IMM 'Set the measurement trigger source to IMMEDIATE.
:TRIGger:ACQuire:COUNT 3 'Set the measurement count to 3.
:OUTPut ON 'Output on
:INITiate:ACQuire 'Start measurement.
:DATA:REM? 3 'Query the measured value.
```

In the line 4, the product switches to measurement trigger wait state, but since the trigger source is set to IMMEDIATE in line 1, measurement starts immediately. Since the measurement count is set to 3 in line 2, measurement is taken three times. When several measurements are taken, use DATA:REM? (line 5) to query the measured values. For the differences in the methods of querying measured values, see “MEASure / READ / FETCh Command” (p.75).

## Starting a measurement with a trigger and querying the results

You can use a trigger to take measurements by setting the measurement trigger source (TRIG:ACQ:SOUR) to anything other than IMMEDIATE. The example here shows that the system starts measurement upon receiving an input by the \*TRG command after the output of the OUTPUT terminal has turned on, then queries the measured value.

```
:TRIGger:ACQuire:SOURce BUS 'Sets the measurement trigger source to BUS
:OUTPut ON 'OUTPUT on
:INITiate:ACQuire 'Switches to measurement trigger wait state
*TRG 'Start measurement
:FETCh? 'Query the measured value
```

This product switches to measurement trigger wait state in line 3. Since the measurement trigger source is set to BUS in Line 1, measurement starts when \*TRG is sent during the trigger wait state.

# Overview of Trigger Function

This product allows you to control the start timing of measurement using triggers. In the trigger wait state, a measurement can be started when an event selected beforehand (trigger source) matches an event either inside or outside this product (trigger).

## Trigger subsystem

There are two trigger systems.

TRANsient	A sequence or step starts using trigger detection as the starting point.
ACQuire	Measurement starts using trigger detection as the starting point.

## Trigger source

The following trigger sources are supported.

IMMEDIATE	Execution starts at the internal timing of this product without waiting for trigger application. The delay until the start of execution is reduced to a minimum.
BUS	Execution starts when a software trigger (*TRG or TRIG:ACQ) is input.
EXTERNAL	The trigger is applied when a trigger signal is input to the EXT CONT connector of PXB series.
MSYNc	Execution starts when a signal is received from an synchronized external equipment or when a TRIG:ACQ:MSYN or TRIG:TRAN:MSYN sync signal is received from a PC or the like.
OFF	Starts the measurement when output off.

# Trigger processing procedure

The trigger processing procedure is illustrated in the following figures.

## Sequence trigger system

When PROGRAM1 and PROGRAM2 are both registered in the chain

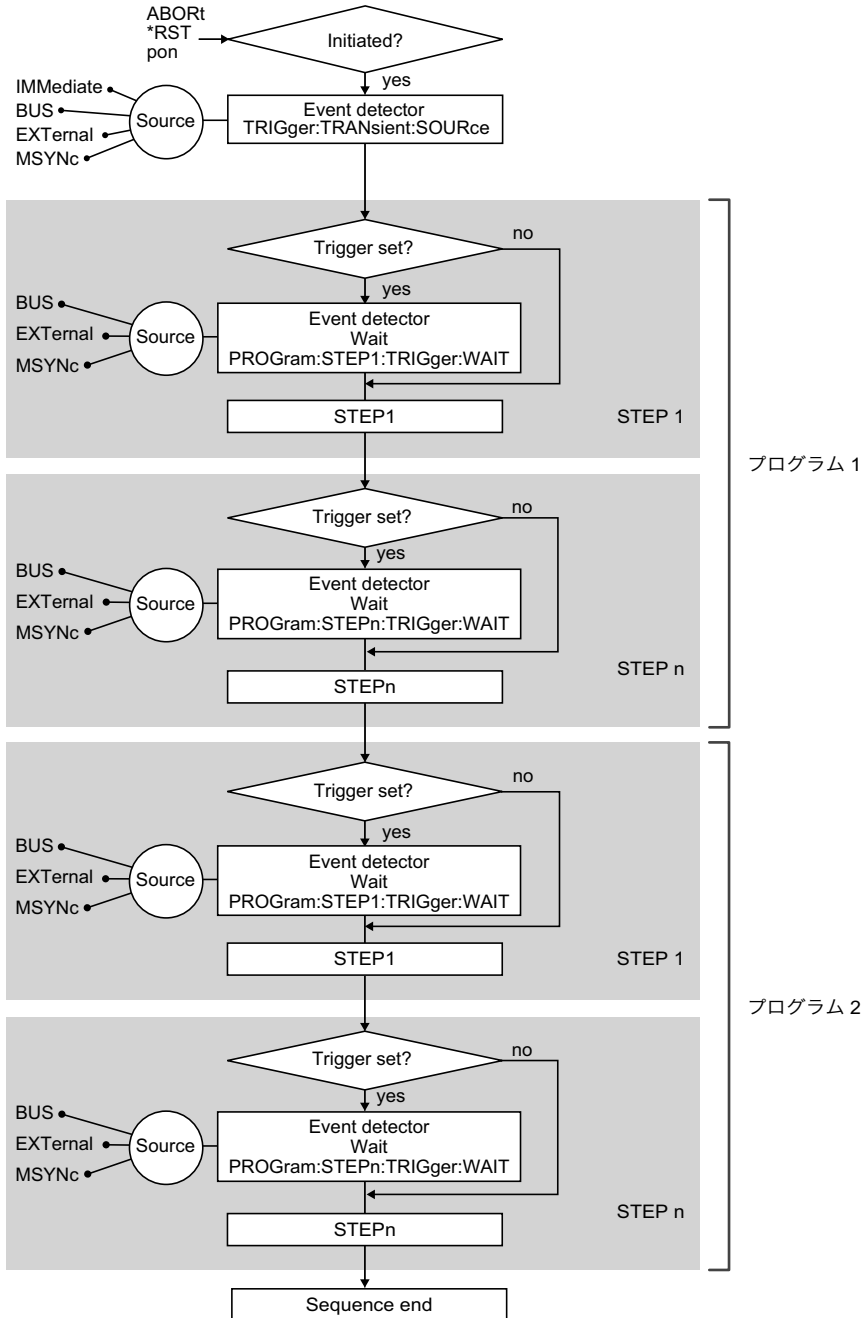

### Measurement trigger system

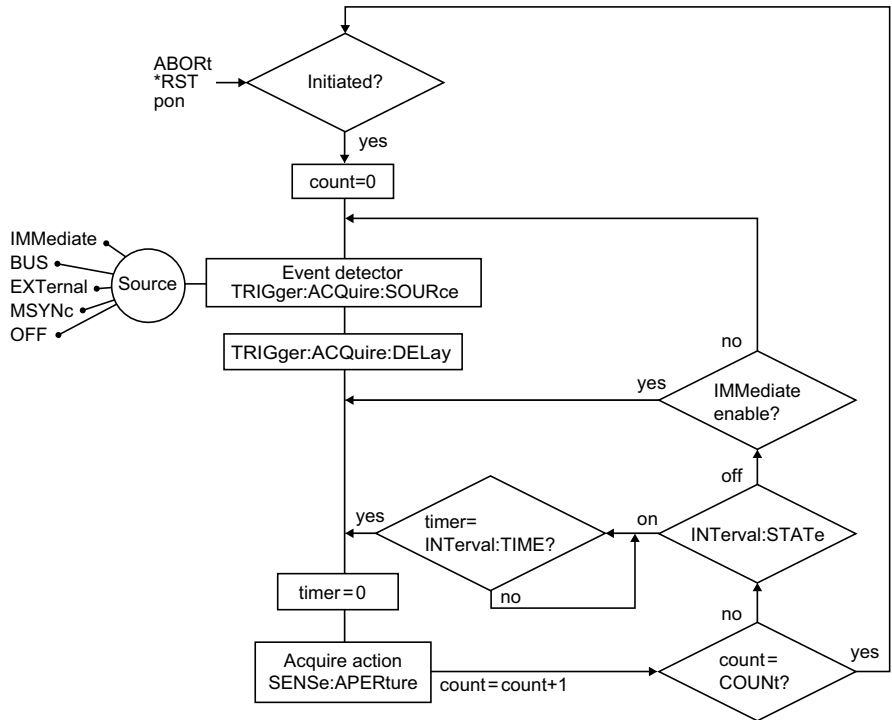

## Sequence operations

A sequence consists of programs and steps. A program is a collection of steps. Steps are executed in order one at a time, starting from step 1. Upon completion of the last step of a program, execution of that program has been completed once. The value at the end of the sequence will be the value of the last step.

You can create up to 30 programs in the product. You can use a combined total of 10 000 steps for all the programs. For an overview of the sequence functions, see the user's manual.

In this example, we will create a sequence that works under the following conditions in constant current (CC) mode.

### Operating condition

Register PROGRAM1 and PROGRAM2 below in the chain.

#### Program 1

Program name: PROGRAM1

Run	Output value	Execution time	Output	Transition method	Trigger output
Step 1	8 A	10 seconds	On	CC	NONE
Step 2	6 A	12 seconds	On	IMMediate	NONE
Step 3	0 A	7 seconds	Off	IMMediate	NONE
Step 4	3 A	15 seconds	On	IMMediate	PSPulse

#### Program 2

Program name: PROGRAM2

Run	Output value	Execution time	Output	Transition method	Trigger output
Step 1	8 A	5 seconds	On	IMMediate	NONE
Step 2	3 A	10 seconds	On	CC	STATe
Step 3	6 A	7 seconds	On	IMMediate	NONE

## Explanation

When registering in the order of PROGRAM1 and PROGRAM2 in the chain, steps 1 to 3 of PROGRAM2 are executed after steps 1 to 4 of PROGRAM1 are executed, and then the sequence ends.

Representing this sequence in graph form looks as follows.

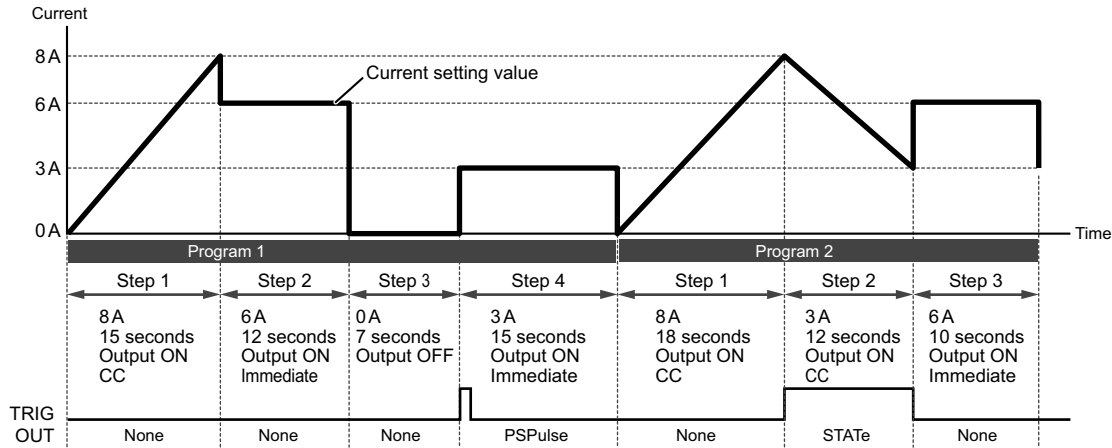

## Example of commands used to create a sequence

### Create PROGRAM1

```

:PROG:NAME "PROGRAM1" 'Create PROGRAM1
:PROG:STEP:COUN 4 'Set the number of steps of PROGRAM1 to 4
:PROG:STEP1:CURR 8A 'Set the setting value of Step 1 to 8 A
:PROG:STEP2:CURR 6A 'Set the setting value of Step 2 to 6 A
:PROG:STEP4:CURR 3A 'Set the setting value of Step 4 to 3 A
:PROG:STEP1:DWEL 15S 'Set the execution time of Step 1 to 15 seconds
:PROG:STEP2:DWEL 12S 'Set the execution time of Step 2 to 12 seconds
:PROG:STEP3:DWEL 7S 'Set the execution time of Step 3 to 7 seconds
:PROG:STEP4:DWEL 15S 'Set the execution time of Step 4 to 15 seconds
:PROG:STEP1:OUTP ON 'Set Step 1 to output on
:PROG:STEP2:OUTP ON 'Set Step 2 to output on
:PROG:STEP3:OUTP OFF 'Set Step 3 to output off
:PROG:STEP4:OUTP ON 'Set Step 4 to output on
:PROG:STEP1:TRAN CC 'Set Step 1 to CC transition
:PROG:STEP2:TRAN IMM 'Set Step 2 to IMMEDIATE transition
:PROG:STEP4:TRAN IMM 'Set Step 4 to IMMEDIATE transition
:PROG:STEP1:TRIG:GEN NONE 'Set the trigger output of Step 1 to NONE
:PROG:STEP2:TRIG:GEN NONE 'Set the trigger output of Step 2 to NONE
:PROG:STEP3:TRIG:GEN NONE 'Set the trigger output of Step 3 to NONE
:PROG:STEP4:TRIG:GEN PULS 'Set the trigger output of Step 4 to PULSe

```

## Create PROGRAM2

```

:PROG:NAME "PROGRAM2" 'Create PROGRAM2
:PROG:STEP:COUN 3 'Set the number of steps of PROGRAM2 to 3
:PROG:STEP1:CURR 8A 'Set the setting value of Step 1 to 8 A
:PROG:STEP2:CURR 3A 'Set the setting value of Step 2 to 3 A
:PROG:STEP3:CURR 6A 'Set the setting value of Step 3 to 6 A
:PROG:STEP1:DWEL 18S 'Set the execution time of Step 1 to 18 seconds
:PROG:STEP2:DWEL 12S 'Set the execution time of Step 2 to 12 seconds
:PROG:STEP3:DWEL 10S 'Set the execution time of Step 3 to 10 seconds
:PROG:STEP1:OUTP ON 'Set Step 1 to output on
:PROG:STEP2:OUTP ON 'Set Step 2 to output on
:PROG:STEP3:OUTP ON 'Set Step 3 to output on
:PROG:STEP1:TRAN CC 'Set Step 1 to CC transition
:PROG:STEP2:TRAN CC 'Set Step 2 to CC transition
:PROG:STEP3:TRAN IMM 'Set Step 3 to IMMEDIATE transition
:PROG:STEP1:TRIG:GEN NONE 'Set the trigger output of Step 1 to NONE
:PROG:STEP2:TRIG:GEN STAT 'Set the trigger output of Step 2 to STATE
:PROG:STEP3:TRIG:GEN NONE 'Set the trigger output of Step 3 to NONE

```

## Register in the chain

```

:PROG:CHA:ADD "PROGRAM1" 'Add PROGRAM1 to the chain
:PROG:CHA:ADD "PROGRAM2" 'Add PROGRAM2 to the chain

```

## Executing and stopping a sequence

Send the following commands to execute a sequence immediately.

```

:TRIG:TRAN:SOUR IMM 'Set the trigger source to IMM.
:INIT:TRAN:PROG 'Start PROGRAM1

```

To stop a sequence that is being executed, send the following command.

```
:ABOR
```

## Executing a sequence using triggers

For example, if you are using a software trigger to execute PROGRAM1, set the trigger source to BUS.

```

:TRIG:TRAN:SOUR BUS 'Set the trigger source to BUS.
:INIT:TRAN:PROG 'Enter wait state for sequence execution trigger
*TRG 'Sends a software trigger and starts the sequence

```

INIT:TRAN:PROG pulls the TRIGGER subsystem out of the IDLE state and places it in the trigger function start (initiated) state.

At that time, if TRIG:TRAN:SOUR is IMM, the sequence is immediately executed by the selected program.

If TRIG:TRAN:SOUR is other than IMM, the state is the trigger wait (WTG) state, and when the source signal set with TRIG:TRAN:SOUR is sent, the sequence is executed by the selected program.

When the sequence completes or is stopped, the TRIGGER subsystem enters the IDLE state again.

## Waiting for Operation Complete

When the \*OPC command is transmitted, this product sets the OPC bit (bit 0) of the event status register to TRUE (1) when the processing of all commands in standby has been completed.

This information can be determined by checking the OPC bit (bit 0) of the \*ESR? query.

Example: Starting a new measurement and transmitting the \*OPC command

When the event status enable register is set to 1 and the service request enable register is set to 32, an SRQ (Service Request) is generated upon measurement completion. The SRQ function cannot be used if you are using the RS232 and SCPI-ROW interfaces.

```
*ESE 1;*SRE 32;*CLS;:INIT:ACQ;*OPC
```

<A service request is generated upon completion of measurement>

When the \*OPC? query command is used instead of the \*OPC command, this product sets response data "1" (in NR1 format) in the output queue upon completion of measurement if there are no other operations waiting to be completed.

```
:INIT:ACQ;*OPC?
```

<Read response upon measurement completion>

When IEEE488 sdc/dcl, \*RST, or \*RCL is transmitted when the power is turned on, this product sets the OPC bit (bit 0) to TRUE (1), and the response data in the output queue to "1" (in NR1 format).

# Status Monitoring

This product has two mandatory SCPI standard registers, STATUS:OPERation and STATUS:QUESTionable, in addition to the IEEE488.2 standard registers.

## Register basics

All SCPI registers have a standard architecture that uses events/filters. CONDition, EVENT, ENABLE, and optionally PTRansition and NTRansition can be used. CONDition and EVENT are read-only registers working as status indicators. ENABLE, PTRansition and NTRansition are read-write registers working as event and summary filters.

### STATUS:OPERation

The OPERation status register is used to record events and notifications that occur during normal operations. For example, to check whether CV mode is in use, check the CV bit (bit 0) of the STATUS:OPERation register.

```
STATUS:OPERation? 'Check whether the CV bit is set
```

When multichannel is in use, check the CV bit (bit 0) of the STATUS:OPERation:INSTrument:ISUMmary<n> subregister.

```
:STATUS:OPERation:INSTrument:ISUMmary2? 'Check whether the CV bit of channel 2 is set
```

### STATUS:QUESTionable

The QUESTionable status register is used to record events and notifications that occur during abnormal operations. To check, for example, whether the overvoltage protection has been activated, check the OV bit (bit 0) of the STATUS:QUESTionable register.

```
STATUS:QUESTionable? 'Check whether the OV bit is set
```

To check which channel is operating overvoltage protection, check the STATUS:QUESTionable:INSTrument subregister when the bit0 is "true" under the Multichannel operation.

```
:STATUS:QUESTionable:INSTrument? 'Check which channel is operating abnormally
```

The channel of a "true" bit of the STATUS:QUESTionable:INSTrument subregister is operating abnormally. By specifying the channel operating abnormally and checking the STATUS:QUESTionable:INSTrument:ISUMmary<n> subregister, you can determine the abnormal content.

```
:STATUS:QUESTionable:INSTrument:ISUMmary2? 'Check whether the OV bit of channel 2 is set
```

## Use Multichannel

If you want to execute a command for a specific channel of Multichannel (p.41), specify the channel in INST. The following commands are executed for the channels specified. Channel 0 is set as the factory default conditions.

Example in which PXB series in channel 2 is configured:

```
:INST 2 'Specifies channel 2
:VOLT 12.0 'Set channel 2 voltage to 12.0 V
:CURR 1.5 'Set channel 2 current to 1.5 A
```

Example in which the measured value of PXB series in channel 3 is queried:

```
:INST 3 'Specifies channel 3
:MEASure:VOLTage? 'Queries the voltage output of channel 3
:MEASure:CURRent? 'Queries the current output of channel 3
```

When you want to execute a command for all channels, use GLOBal command.

```
:GLOB:OUTP 1 'Turns output on for all channels
```

The GLOB:OUTP command turns on/off the output of all channels, but does not synchronize them. If you want to synchronize all outputs, we recommend that you use the synchronization function.

## Error Checking

### Error/event queue

The SCPI specifications define a standard error reporting scheme, error/event queue. This is a FIFO (First In First Out) queue, which records errors and events. The maximum number of errors/events that this product can record is 16. Each error/event can be read with the SYSTem:ERRor query.

```
:SYSTem:ERRor?
```

The response to this query contains a numeric part (error/event number) and a textual description, such as:

```
-222, "Data out of range"
```

The error/event queue becomes empty when the \*CLS common command is sent, when the last item in the queue is read, or when this product is turned on. When the error/event queue is empty, the query returns the following:

```
0, "No error"
```

### Displaying communication errors

When an SCPI error occurs, you can check the error on the display by pressing Status > SCPI Status on the homepage.

This is convenient for debugging remote control.

## When Using Commands on a PLC (sequencer, controller)

These are notes for when using commands on a PLC (sequencer, controller).

- Append a delimiter (ASCII 0x0A) to each command.
- When using RS232C, match the protocol with the sequencer setting.
- Return values vary in length. Because exponential (NR3) queries are also available, processing using functions is necessary on the sequencer side.

# Appendix

## List of Errors

### Standard SCPI errors

#### Command error

An error in the range [-199, -100] indicates that an IEEE 488.2 syntax error has been detected by the instrument's parser. The occurrence of any error in this class causes the Command Error bit (bit 5) in the event status register to be set.

Error code		Error message description
-103	Invalid separator	Invalid separator. The parser was expecting a separator and encountered an illegal character.
-108	Parameter not allowed	Parameter not allowed. More parameters were received than expected for the header.
-109	Missing parameter	Missing parameter. Fewer parameters were received than required for the header.
-112	Program mnemonic too long	Mnemonic too long. The number of characters in the command header exceeds 12 characters.
-113	Undefined header	Undefined header. Inappropriate for this product.
-120	Numeric data error	Numeric data error. Generated when parsing a data element which appears to be numeric, including the non-decimal numeric types.
-128	Numeric data not allowed	Numeric data is not allowed.
-131	Invalid suffix	A suffix is invalid. The suffix does not follow the syntax, or the suffix is inappropriate for this product.
-138	Suffix not allowed	A suffix was encountered after a numeric parameter that does not allow suffixes.
-141	Invalid character data	The character data is invalid.
-144	Character data too long	Character data too long. The character data element contains too many characters.
-150	String data error	String data error. Generated when parsing a string data element.
-158	String data not allowed	String data is not allowed.
-161	Invalid block data	The block data is invalid.
-171	Invalid expression	String in the parentheses contains an illegal character.

## Execution error

An error in the range [-299, -200] indicates that an error has been detected by the instrument's execution control block. The occurrence of any error in this class causes the Execution Error bit (bit 4) in the event status register to be set.

Error code		Error message description
-200	Execution error	Execution error.
-211	Trigger ignored	A trigger was received but ignored.
-213	Init ignored	A measurement initiate operation was ignored because measurement is in progress.
-214	Trigger deadlock	A deadlock occurred because a query was received before the software trigger.
-220	Parameter error	Invalid parameter.
-221	Settings conflict	A command was received that this product cannot execute in its present operating status.
-222	Data out of range	Parameter was out of range.
-224	Illegal parameter value	Received invalid parameter data.
-230	Data corrupt or stale	Received a data query before the measurement completed.
-241	Hardware missing	Cannot be executed because the optional hardware is not installed.
-282	Illegal program name	The program name is illegal.
-284	Program currently running	The program is running.
-292	Referenced name does not exist	There is no name for reference.
-293	Referenced name already exists	A name that already exists.

## Device-specific errors

An error in the range [-399, -300] indicates that an error other than command error, query error, or execution error was detected. The occurrence of any error in this class causes the Device Dependent Error bit (bit 3) in the event status register to be set.

Error code		Error message description
-310	System error	System error.
-311	Memory error	Memory error. Physical damage to the device memory.
-314	Save/recall memory lost	The data that was saved with the *SAV command has been lost.
-315	Configuration memory lost	The system settings data has been lost.
-330	Self-test failed	An error occurred during the self-test.
-350	Queue overflow	Queue overflow.
-361	Parity error in program message	Parity error on RS232C.
-363	Input buffer overrun	Buffer overflow error. This is an error when using RS232C.

## Query error

An error number in the range [-499, -400] indicates that the output queue control of the instrument has detected a problem with the message exchange protocol described in IEEE 488.2, chapter 6. The occurrence of any error in this class causes the Query Error bit (bit 2) in the event status register to be set.

Error code		Error message description
-410	Query INTERRUPTED	Received a new command after the query was received and before the response was read.

## Product-specific errors

The occurrence of any error in this class causes the Device Dependent Error bit (bit 3) in the event status register to be set.

### Configuration conflict errors and configuration change rejection errors

These errors occur when the specified configuration changes cannot be permitted.

Error code		Error message description
+102	Conflicts with OUTPut ON state	Configuration is not possible because OUTP/INP is set to ON.
+110	Conflicts with VOLT:FUNC:MODE setting	Configuration is not possible because of the VOLT:FUNC:MODE setting.
+111	Conflicts with CURR:FUNC:MODE setting	Configuration is not possible because of the CURR:FUNC:MODE setting.
+112	Conflicts with POW:FUNC:MODE setting	Configuration is not possible because of the POW:FUNC:MODE setting.
+114	Overlaid peak value of AMPLitude and OFFSet components is too large	Due to the AMPLitude and OFFSet settings, the peak value is outside the setting range and settings cannot be configured.
+120	Discharge currently processing	Configuration is not possible because discharging is in progress.
+160	Conflicts with PROTection state	Cannot be set because a protection function is activated.
+161	Conflicts with LINE_UVP state	Configuration is not possible because LUVF alarm is activated.
+170	VOLT:PROT setting conflicts with UVP setting	Configuration is not possible because VOLT:PROT is disabled by the UVP setting.
+171	VOLT:PROT:LOW setting conflicts with OVP setting	Configuration is not possible because VOLT:PROT:LOW is disabled by the OVP setting.
+212	Conflicts with ACQuire in progress	Configuration is not possible because a ACQuire subsystem is running.
+280	Invalid IV map data index	The index of the I-V map data is invalid.
+281	IV map data number out of range	The I-V map data number is out of range.
+282	Invalid IV map data	The I-V map data is invalid.
+283	Currently applying IV map data	I-V map data is being applied.
+301	Program is unselected	No program is selected.
+302	Program chain is empty	The program chain is empty.
+303	Invalid STEP index	The step index is invalid.
+304	Too many steps	The number of steps is too large.
+305	Too few steps	The number of steps is too low.
+306	TRANSient is not operating	The TRANSient is not operating.
+307	TRANSient is not paused	TRANSient is not paused.
+500	Conflicts with IO:STAT	Configuration is not possible because of the IO:STAT setting.
+550	Conflicts with DATA:INT:GATE state	Configuration is not possible due to the state of DATA:INT:GATE.
+551	Conflicts with DATA:INT:GATE:RES state	Configuration is not possible due to the state of DATA:INT:GATE:RES.
+600	Conflicts with *RST	Configuration is not possible because *RST is being executed.
+601	Conflicts with *RCL	Configuration is not possible because *RCL is being executed.

### Errors related to the self-test function

Error code		Error message description
+901	EEPROM MODEL info lost	Model information was lost.
+902	EEPROM CALIBRATION info lost	Calibration information was lost.

## Command Processing Time

A certain amount of time is required before the commands shown in the following table are received by this product. The processing times indicated here are standard values. They are not guaranteed.

The processing times vary depending on the settings and the measurement conditions.

Command	Processing time (ms)			
	USB	RS232C <sup>1</sup>	LAN (SCPI-RAW)	LAN (HiSLIP)
VOLT <sup>2 3</sup>	1.9	1.6	1.9	1.62
OUTP ON <sup>3</sup>	3.0	3.1	3.3	3.5
OUTP OFF <sup>3</sup>	1.2	1.5	2.0	2.0
MEAS? <sup>4</sup>	110	180	120	111
OUTP? <sup>4</sup>	36	20	30	19

1. The baud rate is 19200.
2. VOLT:RESP is set to FAST.
3. Time required before the voltage starts rising after the command terminator is sent.
4. Time required before the PC receives the response after sending the command.

### When command processing time is slow

IO:OUTP:FUNC is set to DIN and IO:STAT is set to ON, the command processing time becomes slow as shown below. MEAS? and OUTP? do not affect the processing time.

Command	Processing time (ms)			
	USB	RS232C <sup>1</sup>	LAN (SCPI-RAW)	LAN (HiSLIP)
VOLT <sup>2 3</sup>	3.2	3.4	3.6	3.8
OUTP ON <sup>3</sup>	4.9	4.9	5.3	5.5
OUTP OFF <sup>3</sup>	3.1	3.4	3.5	3.6

1. The baud rate is 19200.
2. VOLT:RESP is set to FAST.
3. Time required before the voltage starts rising after the command terminator is sent.



Every effort has been made to ensure the accuracy of this manual. However, if you have any questions or find any errors or omissions, please contact your Kikusui agent or distributor.

After you have finished reading this manual, store it so that you can use it for reference at any time.

## **KIKUSUI ELECTRONICS CORP.**

---

1-1-3 Higashiyamata, Tsuzuki-ku, Yokohama,  
224-0023, Japan

Phone: +81-45-482-6353

Facsimile: +81-45-482-6261

**[global.kikusui.co.jp](http://global.kikusui.co.jp)**

