

50 Ω High Power VSWR Bridge



1 Introduction

The TBSWR-60K500 high power VSWR - bridge is designed for forward / reverse power measurement in EMC immunity test setups with BCI probes (Substitution Method) and general high power applications in the HF and VHF range. The bridge combines the wide frequency range and directivity of a directional bridge and the low insertion loss and power handling capability of a directional coupler.

The TBSWR-60K500 is characterized in the frequency range from 60 kHz to 500 MHz. The high power handling capability of up to 200W allows inline RF power measurements, and a variety of other applications. The insertion loss over the frequency range is typically between 0.15 and 0.6 dB, which is significantly smaller than the average 7 dB associated with VSWR - bridges.

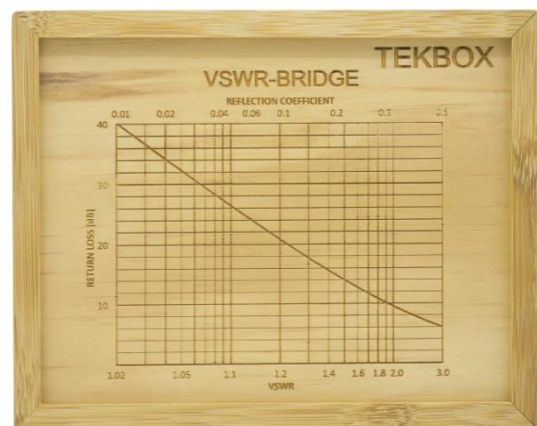

2 Typical data

Characterized frequency range: 60 kHz – 500 MHz

Directivity:	60 kHz – 500 MHz	> 20 dB	Coupling:	60 kHz – 100 MHz	-50 dB ± 0.7 dB
	150 kHz – 300 MHz	> 25 dB		100 MHz – 500 MHz	-50 dB + 0.7/- 10 dB
	200 kHz – 30 MHz	> 30 dB			

Insertion loss:	60 kHz – 200 MHz	< 0.15 dB	Max. power:	60 kHz – 200 MHz	200 W CW *)
	200 MHz – 500 MHz	< 0.6 dB		200 MHz – 500 MHz	100 W CW *)

*) Short time (max. 1 minute): 350 W
Output shorted or open: max. 80 W

Operating temperature range:	- 20 °C to + 40 °C
Impedance:	50 Ω
Port matching:	> 20 dB
RF connectors, through ports:	N-female
RF connectors, coupling ports:	SMA-female
Dimensions:	113 mm x 60 mm x 35 mm
Weight:	290 g



50 Ω High Power VSWR Bridge

3 Measurement Plots

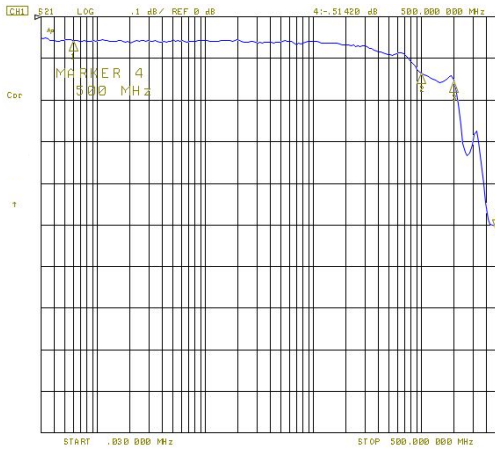

Insertion loss

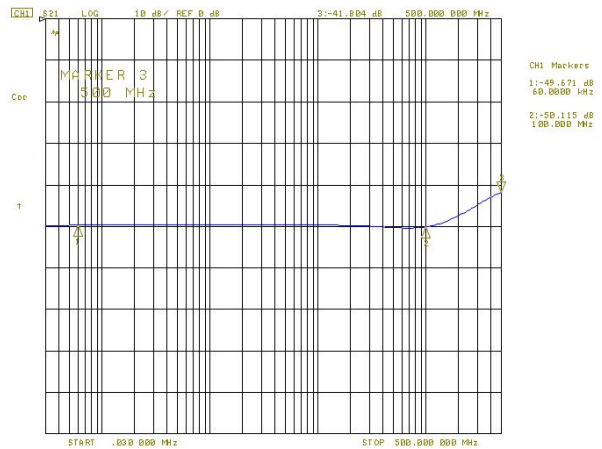

Coupling

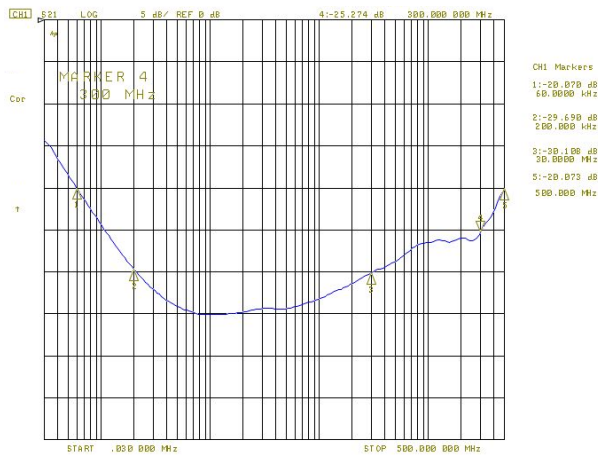

Directivity

4 Operating principle

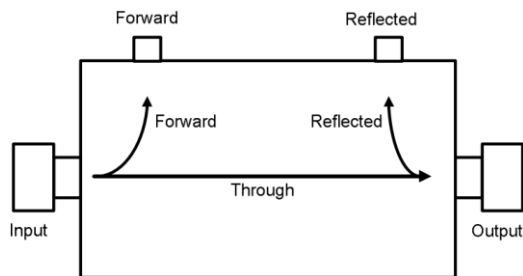

The ports Input/Output and Forward/Reflected can be exchanged. However, directivity may deviate from the documented values.

50 Ω High Power VSWR Bridge

5 Mechanical Drawing

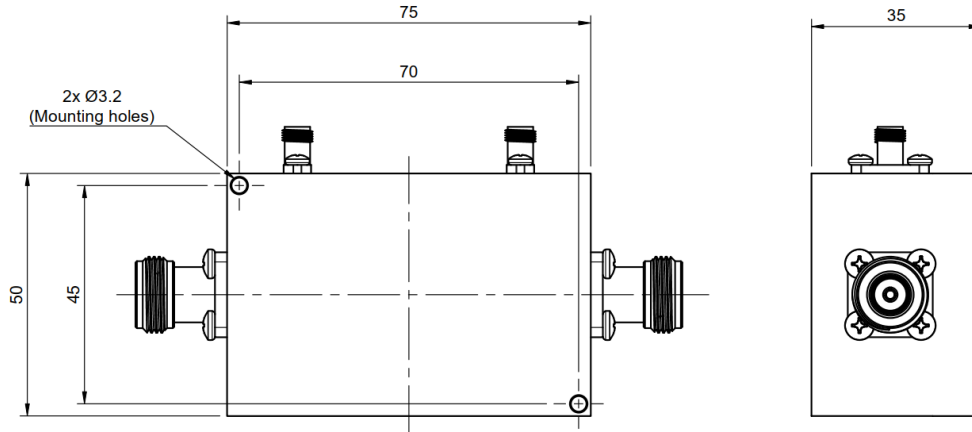

6 Ordering Information

Part Number	Description
TBSWR-60K500	VSWR – Bridge, 60 kHz – 500 MHz, 200 W; wooden box, 2 pcs SMA terminations

7 History

Version	Date	Author	Changes
V1.0	20.11.2023	Mayerhofer	Creation of the document