

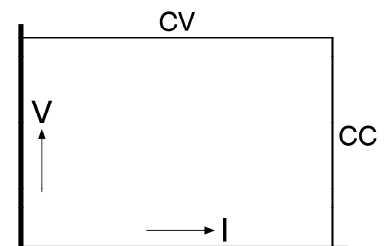

ES 150 - Series 150W DC POWER SUPPLIES

Models	Voltage range	Current range
ES 015-10	0 - 15 V	0 - 10 A
ES 030-5	0 - 30 V	0 - 5 A
ES 075-2	0 - 75 V	0 - 2 A
ES 0300-0.45	0 - 300 V	0 - 0.45 A



Features

- Very low output ripple and spikes
- EMC surpasses CE requirements:
low emission & high immunity
- High programming speed
- Excellent dynamic response to load changes
- Protected against all overload and short circuit conditions
- Designed for a long life at full power

Functionalities

- Voltage and current control with 10 turn potentiometers
- Master/Slave parallel and series operation with
voltage and current sharing
- 19" rack mounting or for laboratory use
(feet included)
- Optional Remote sensing
- Convection cooling

	ES 015-10	ES 030-5	ES 075-2	ES 0300-0.45
Output voltage current	0 - 15 V 0 - 10 A	0 - 30 V 0 - 5 A	0 - 75 V 0 - 2 A	0 - 300 V 0 - 450 mA
Input AC single phase, 48 - 62 Hz rated voltage range rated frequency Input current @ 230 VAC power factor, 110 / 230 VAC full load DC internal fuses standby input power (Vo=Io=0) standby input power (Vo=Vmax)	90 - 265 V 100 - 240 V 50 / 60 Hz 1 A 0.99 / 0.83 contact factory 4 AT 6 W 11 W			
Efficiency AC 230 V input, full load AC 110 V input, full load	83 % 80 %	84 % 82 %	84 % 81 %	84 % 81 %
Regulation				
Load 0 - 100% internal sensing optional external sensing	CV 15 mV 2 mV	6 mV 2 mV	5 mV 5 mV	10 mV 10 mV
Line 90 - 265 V AC	CV 0.2 mV	0.5 mV	1 mV	3 mV
Load 0 - 100% Line 90 - 265 V AC (internal voltage sensing)	CC 3 mA 0.5 mA	1 mA 0.2 mA	0.5 mA 0.1 mA	0.3 mA 0.05 mA
Ripple + noise (full load) rms (BW=300 kHz) p-p (BW=20 MHz) rms (BW=300 kHz) p-p (BW=20 MHz)	CV 0.5 mV 8 mV CC 1.5 mA 10 mA	0.6 mV 10 mV 0.5 mA 2 mA	1 mV 15 mV 0.1 mA 0.5 mA	7 mV 50 mV (typical 30 mV) 0.03 mA 0.2 mA
Temp. coeff., per °C	CV CC	5.10 ⁻⁵ 10.10 ⁻⁵		
Stability after 1 hr warm-up during 8 hrs t _{amb} = 25 ± 1 °C, Vin = 230 VAC (internal voltage sensing for CC-stab.)	CV CC 10.10 ⁻⁵ 10.10 ⁻⁵	10.10 ⁻⁵ 10.10 ⁻⁵	10.10 ⁻⁵ 10.10 ⁻⁵	10.10 ⁻⁵ 10.10 ⁻⁵

Analog Programming	CV	CC
Programming inputs input range accuracy offset temp. coeff. offset input impedance	0 - 5 V ± 0.2% 0 ... + 3 mV (on 5 V) 10 µV / °C 1 MOhm	0 - 5 V ± 0.8% 0 ... + 10 mV (on 5 V) 60 µV / °C 1 MOhm
Monitoring output output range accuracy offset temp. coeff. offset output impedance	0 - 5 V ± 0.2% - 2 ... + 2 mV (on 5 V) 10 µV / °C 2 Ohm / max. 4 mA	0 - 5 V ± 0.8% - 10 ... 0 mV (on 5 V) 60 µV / °C 2 Ohm / max. 4 mA

Reference voltage on prog. connector	V_{ref} TC	$5.137 \pm 10 \text{ mV}$ ($R_o = 2 \text{ Ohm}$, max. 4 mA) 50 ppm
+12 V output on prog. Connector	V_o R_o	$12 \text{ V} \pm 0.5 \text{ V}$ 100 Ohm

Status output CC - status	CC - operation	5 V / 5 mA = logic 1
Remote shutdown		with + 5 V, 1 mA or relay contact
Indicators (front panel)		CV-mode, CC-mode
Controls (front panel)		Mains on/off, CV- and CC-potmeter

	ES 015-10	ES 030-5	ES 075-2	ES 0300-0.45
Programming speed (resistive load)				
Rise time (10 - 90%) output voltage step	0 → 15 V	0 → 30 V	0 → 75 V	0 → 300 V
time, (100% load)	7 ms	15 ms	17 ms	10 ms
time, (10% load)	3 ms	6 ms	7 ms	4 ms
Fall time (90 - 10%) output voltage step	15 → 0 V	30 → 0 V	75 → 0 V	300 → 0 V
time, (100% load)	7 ms	15 ms	17 ms	10 ms
time, (10% load)	70 ms	150 ms	160 ms	100 ms

	ES 015-10	ES 030-5	ES 075-2	ES 0300-0.45
Recovery time recovery within di/dt of load step time, @ 50 - 100% load step max. deviation @ 230 VAC input voltage	50 mV 250 mA/μs 100 μs 160 mV	50 mV 125 mA/μs 100 μs 160 mV	50 mV 70 mA/μs 100 μs 150 mV	200 mV 6 mA/μs 130 μs 700 mV
Output impedance CV, 0-100 kHz	< 100 mOhm	< 200 mOhm	< 250 mOhm	< 5 Ohm
Pulsating load max. tolerable AC component of load current f > 1 kHz f < 1 kHz	2 A rms 10 A peak	2 A rms 5 A peak	2 A rms 2 A peak	2 A rms 0.45 A peak

Insulation input / output creepage / clearance	3750 Vrms (1 min.) 8 mm
input / case output / case	2500 Vrms 600 V DC
Safety	EN 60950 / EN 61010
EMC Power Supply Standard	EN 61204-3 , Emission: residential, light industrial environment (CISPR22-Class B) Immunity: industrial environment
Generic Emission Generic Immunity	EN 61000-6-3 , residential, light industrial environment (EN 55022 B) EN 61000-6-2 , industrial environment
Operating Temperature at full load	- 20 to + 50 °C derate output to 75% at 60 °C
Humidity	max. 95% RH, non condensing, up to 40 °C max. 75% RH, non condensing, up to 50 °C
Storage temperature	- 40 to + 85 °C
Thermal protection	Output shuts down in case of insufficient cooling
MTBF	500 000 hrs

Hold-Up time (230 VAC input) Vout = 100% , Iout = 100% Vout = 85% , Iout = 100% Vout = 100% , Iout = 50%	25 ms 40 ms 60 ms
Turn on delay (230 VAC input) after mains switch on	250 ms
Inrush current	10 A with NTC resistor 30 Ohms cold resistance

	ES 015-10	ES 030-5	ES 075-2	ES 0300-0.45
Series operation max. total voltage Master / Slave operation	600 V with optional external Master / Slave Adapter			
Parallel operation max. total current Master / Slave operation	no limit max. 4 units			
Remote sensing (optional)	option P119	option P120	option P121	option P122
max. voltage drop per load lead	2 V <i>Note: voltage drop across load leads will subtract from max. available output voltage</i>			
Over Voltage Limit (fixed)	max. 18 V	max. 40 V	max. 90 V	max. 330 V
Potentiometers front panel control with knobs resolution screwdriver adjustment at front panel	standard 0.03% option P001			
Meters scale voltage scale current accuracy V-meter accuracy A-meter	3.5 digit 0 - 15.00 V 0 - 10.00 A 0.5% + 2 digits 1% + 2 digits	3.5 digit 0 - 30.0 V 0 - 5.00 A 0.5% + 2 digits 1% + 2 digits	3.5 digit 0 - 75.0 V 0 - 2.00 A 0.5% + 2 digits 1% + 2 digits	3.5 digit 0 -300 V 0 - 450 mA 0.5% + 2 digits 1% + 2 digits

Input Connector	Euro-connector at rear panel 10 Amp / 65 °C IEC320/C14, EN60320/C14
DC Output Terminals	Standard:4 mm safety sockets at front-panel Option: screw terminals (0.2-4 mm ²) at rear-panel (sockets at front removed) only combined with remote sensing, see remote sensing for option numbers (P119 - 122).
Programming connector	15 pole D-connector at rear panel (FEMALE)
Cooling	Convection cooling
Enclosure degree of protection	IP20
Dimensions (h x w x d)	52 x 222 x 202 mm
Weight	1.7 kg

CV = Constant Voltage
CC = Constant Current

OVL = Over Voltage Limit

Specifications measured at $t_{amb} = 25 \pm 5 \text{ }^\circ\text{C}$ and $V_{in} = 230 \text{ VAC}$, 50 Hz unless otherwise noted.

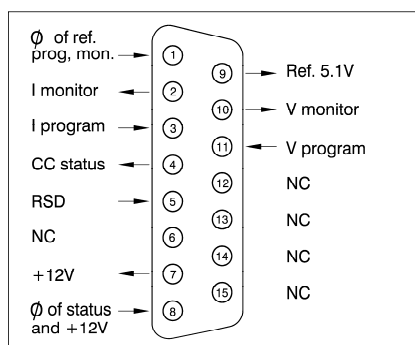

Connections programming connector

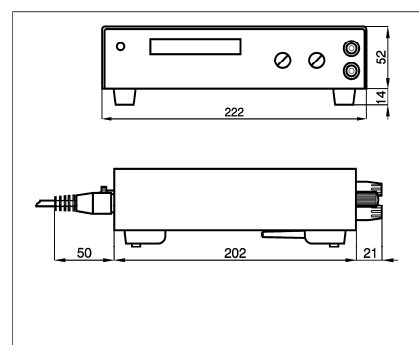

Dimensions

Typical Applications

- Test and measurement
- Component device testing
- Controlled battery charging
- ATE in industrial production lines
- Electronic Circuit Development
- Laboratory analysis
- Medical research equipment
- Accurate current sources

Available Options



Increased Output Power

The conservatively rated unit allows to deliver extra output with the same reliability. At some

derating, either the maximum output voltage or the maximum output current can be increased by about 10%.

- Order Code - P069

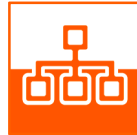

Sequencer

Arbitrary Waveform generator or standalone automation. The sequencer is integrated in the Ethernet controller.

- Order Code - P150



Secured Voltage and Current Setting

For a maximum security, the CV/CC settings can be adjusted with a screwdriver only and are protected

with a plastic cap from accidental adjusting.

- Order Code - P001



Rear Power Output and Remote Sensing

Output terminals at the rear panel instead of bind posts at the front panel, includes remote sensing.

- Order Code ES015-10 - P119
- Order Code ES030-5 - P120
- Order Code ES075-2 - P121
- Order Code ES0300-0.45 - P122



19" Rack Mounting Adapter

Using the 19" mounting adapters, it is possible to position the ES units in a 19" rack. Several

configurations possible with multiple ES and / or PSC or ISO AMP modules.



Software control and Interfaces

Interfaces to be installed by factory:

- RS232 controller - P148
- Ethernet (+ sequencer) - P150
- PROFIBUS controller - P279
- CANBUS controller - P280

External programming interface modules:

- IEEE488 controller module
- ISO AMP module

Notes: 1. Download the special datasheet about Battery Charging from <http://www.DeltaPowerSupplies.com/>.
2. There is only room for one of the interfaces in a unit, see next page for configurations.

19" rack mounting



Rear Connections

Linecord supplied

Input connector

Standard unit:
Analog programming

Switches Manual / Programming
Analog programming

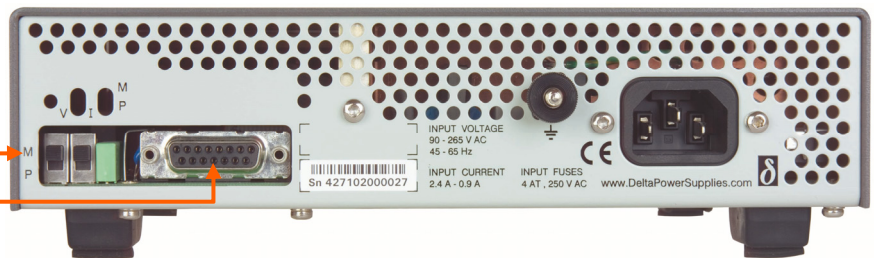

Option P150:
Ethernet programming

Ethernet programming
Switches Manual / Programming
To combine with Option P119-122

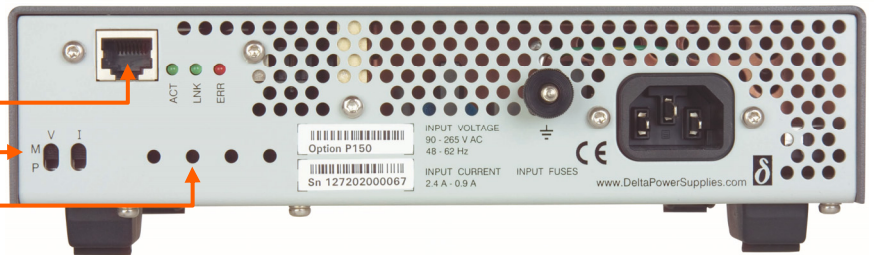

Option P148:
RS232 programming

Switches Manual / Programming
RS232 programming
To combine with Option P119-122

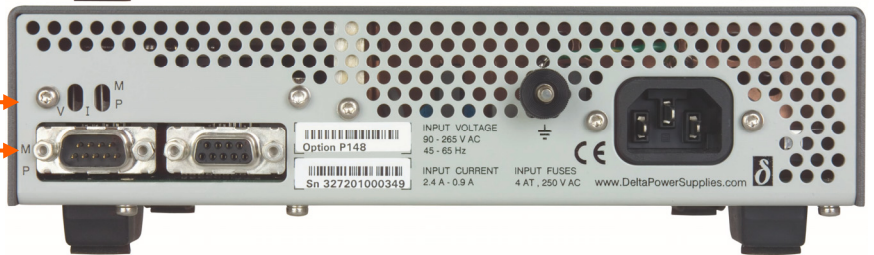

Option P119 - 122:
Rear power outlet /
Remote sensing

Rear power out / Remote sensing
Switches Manual / Programming
Analog programming

